

ROTARY MOWERS
J45, K45, L45 AND M45
J48, K48, L48, M48
Parts Catalog No. 8-1301

9-84-RP-1500-027

NOTE: This catalog replaces catalog 8-1300.

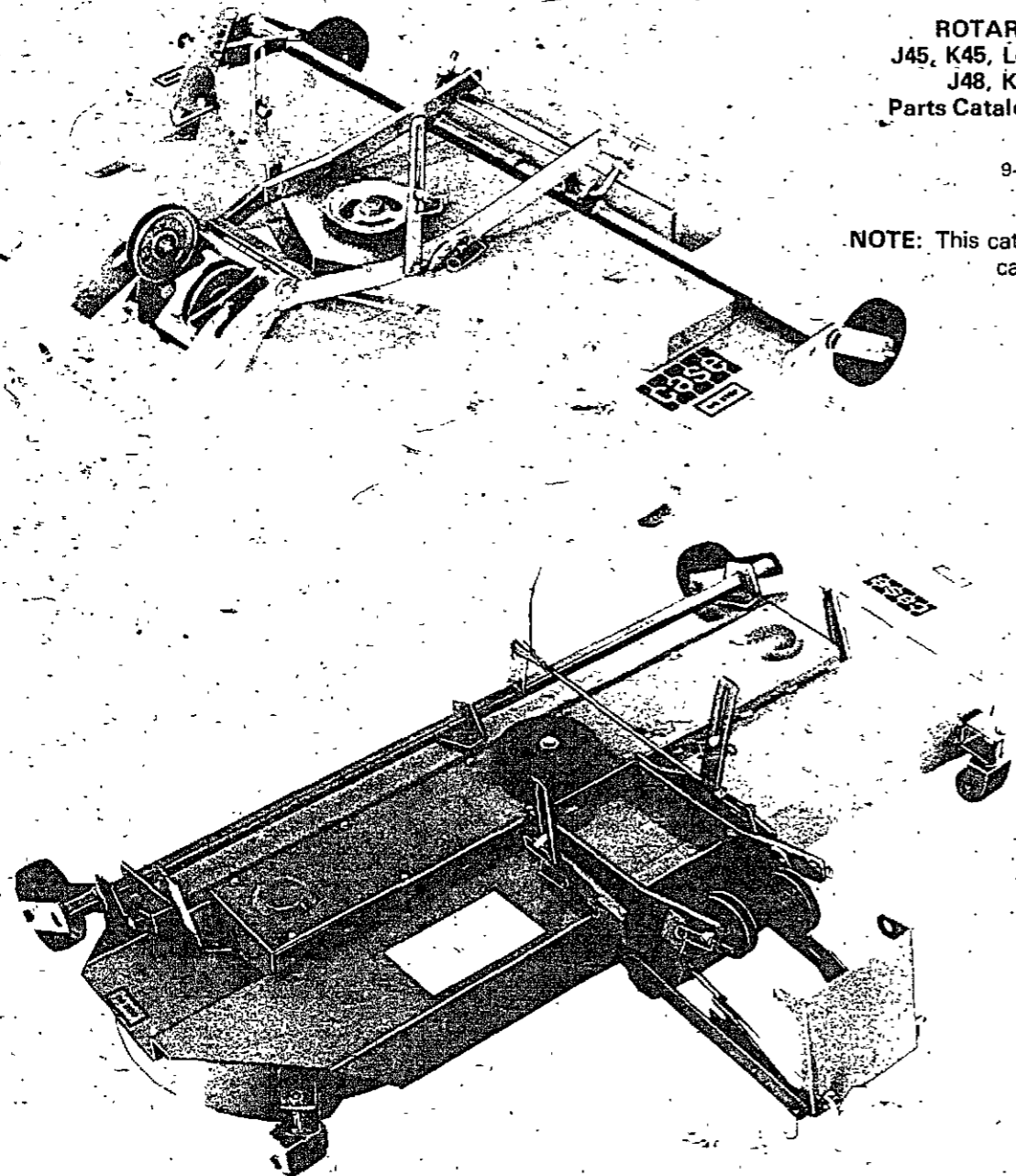

ALPHABETICAL INDEX

MODEL J45, K45, L45 AND M45 ROTARY MOWER

	PAGE	GRID
Axles	9	A8
Bearings, Spindle	7	A6
Belts	5	A4
Blades	7	A6
Chassis	5	A4
Decals	19	B4
Guards and Covers	5	A4
Housing, Spindle	7	A6
Lift Links	9	A8
Pulleys, Deck	7	A6
Pulleys, Idler	9	A8
Spindles	7	A6
Wheels	9	A8

MODEL J48, K48, L48 AND M48 ROTARY MOWER

Axles	15-17	A14-B2
Bearings, Spindle	13	A12
Belts	11	A10
Blades	13	A12
Chassis	11	A10
Decals	19	B4
Guards and Covers	11	A10
Housing, Spindle	13	A12
Lift Links	15-17	A14-B2
Pulleys, Deck	13	A12
Pulleys, Idler	15-17	A14-B2
Rollers, Rubber	11	A10
Spindles	13	A12
Wheels	15-17	A14-B2

NOTE: See grid C2 for 2480, 2486 Wing Mower

APPLICATION CHART

MOWER	TRACTOR MODEL										
	210	220	222	224	226	444	446	448	644	646	648
J45, K45, L45, M45	X	X	X	X	X	X	X	X	X	X	X
J48, K48, L48, M48							(1)	(1)			

(1) use on tractors
 446 P.I.N. 9770165 and after
 448 P.I.N. 9774000 and after

INGERSOLL
 Ingersoll Equipment Co., Inc.

Technical Publications
 119 South First Street
 Winneconne, WI 54986-9576

CHASSIS, BELTS AND CHASSIS COVERS

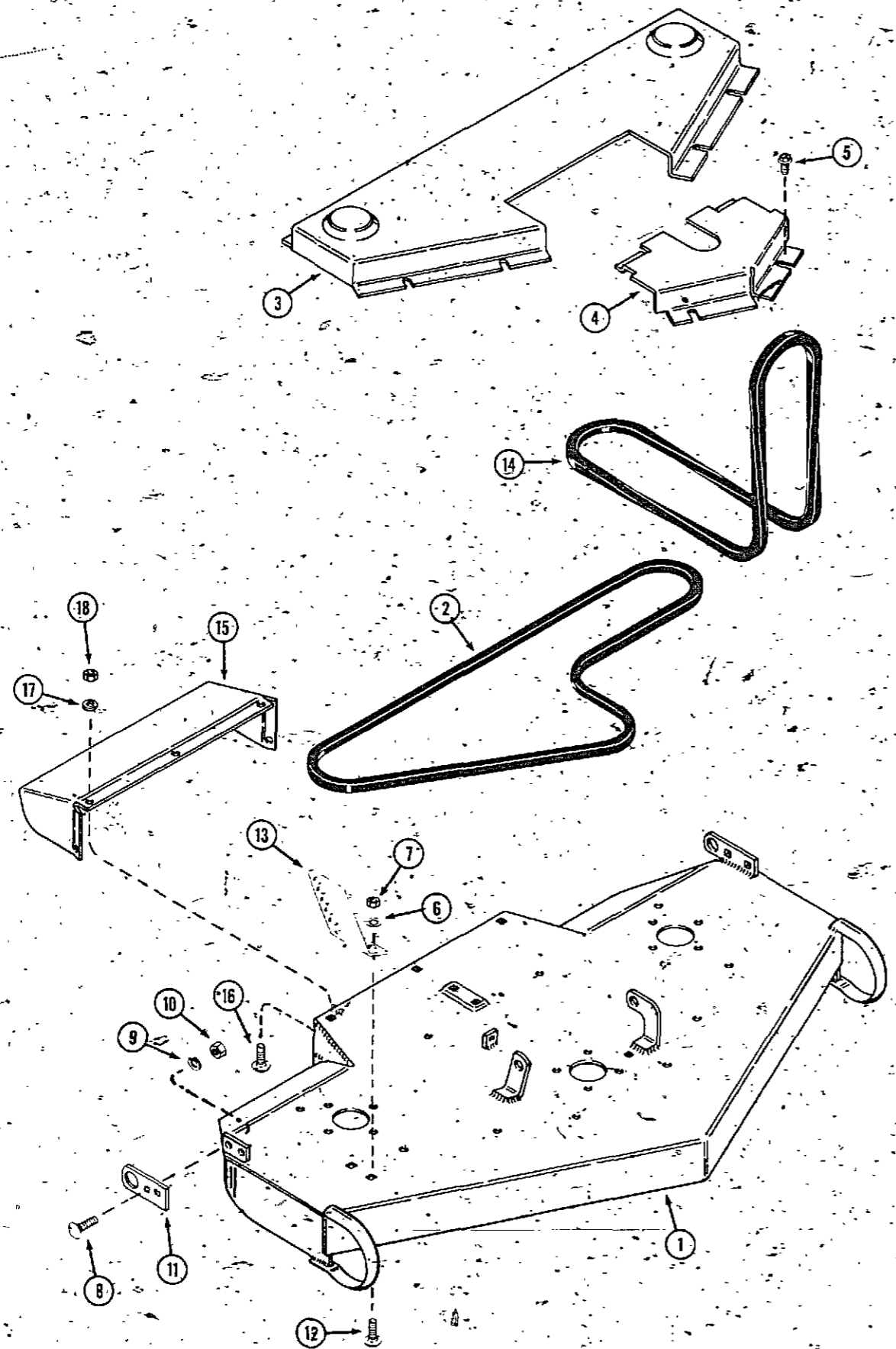

REF	PART NO.	DESCRIPTION	REQ'D
1	C 25394	CHASSIS - mower	1
2	C 22707	BELT - mower chassis	1
3	C 25406	GUARD - chassis belt	1
4	C 25407	COVER - chassis, small	1
5	187- 1036	SCREW - 1/4" x 1/2" NC hex, self-tapping	12
6	193- 29	LOCK WASHER - 5/16" internal tooth	2
7	129- 102	NUT - 5/16" NC hex	2
8	111- 371	BOLT - 3/8" x 1" NC round head, square neck	2
9	192- 21	LOCK WASHER - 3/8"	2
10	129- 103	NUT - 3/8" NC hex	2
11	C 15560	BRACKET - axle pivot	1
12	111- 132	BOLT - 5/16" x 3/4" round head, square neck	2
13	C 25408	BRACKET - height adjust	1
14	C 23358	BELT - drive (use with 210, 220, 222, 224 and 226 tractors)	1
14	C 23359	BELT - drive (use with 444, 446 and 448 tractors)	1
14	C 23808	BELT - drive (use with 646, 648 tractor)	1
14	C 23810	BELT - drive (use with 644 P.I.N. 9698343 and after)	1
14	C 23807	BELT - drive (use with 644 before P.I.N. 9698343)	1
15	C 25409	DEFLECTOR	1
16	111- 101	BOLT - 1/4" - 20 x 5/8"	5
17	192- 19	LOCK WASHER - 1/4"	5
18	129- 101	NUT - 1/4" - 20	5
	C 25402	SKID - rear	1

PULLEYS, BLADES AND SPINDLES

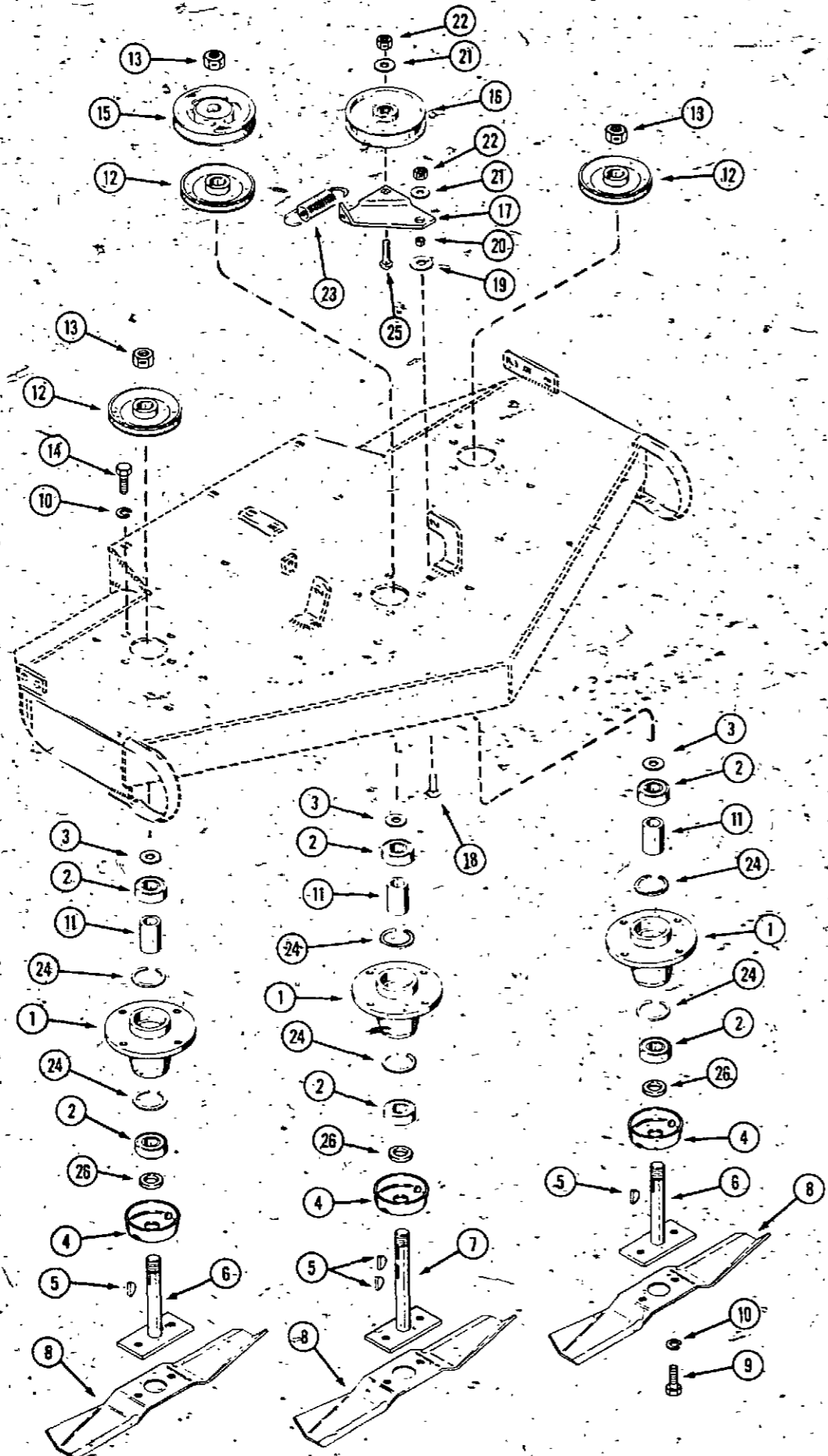

REF.	PART NO.	DESCRIPTION	REQ'D
1	C 17666	HOUSING - mower spindle (also use [2]C16516 S/N CC11119 and after)	3
2	A 70280	BEARING - spindle	6
3	A 70282	WASHER - bearing seal	3
4	C 25543	SHIELD - bearing	3
5	126- 19	KEY - spindle, #11 Woodruff	4
6	C 15763	SPINDLE - outboard	2
7	C 15604	SPINDLE - center	1
8	C 24442	BLADE - 15-1/2"	3
9	113- 206	BOLT - 3/8" x 3/4" NC hex (grade 5)	6
10	192- 21	LOCK WASHER - 3/8"	18
11	C 10810	SPACER - bearing	3
12	C 21581	PULLEY - spindle	3
13	131- 1331	NUT - jam'lock 3/4" NF hex	3
14	113- 206	BOLT - 3/8" x 3/4" NC hex	12
15	C 15615	PULLEY - drive	1
16	C 12251	PULLEY - deck idler	1
17	C 25080	BRACKET - idler	1
18	111- 371	BOLT - 3/8" x 1" carriage, short neck	1
19	195- 105	WASHER - 1/2" ZP	1
20	C 14768	SPACER - idler bracket	1
21	195- 525	WASHER - 3/8" ZP	2
22	131- 1181	NUT - lock 3/8" NC hex	2
23	C 14482	SPRING - idler	1
24	C 16516	RING - retainer	6
25	111- 366	BOLT - 3/8" x 1-1/4" carriage, short neck	1
26	C 25541	SPACER - spindle	3

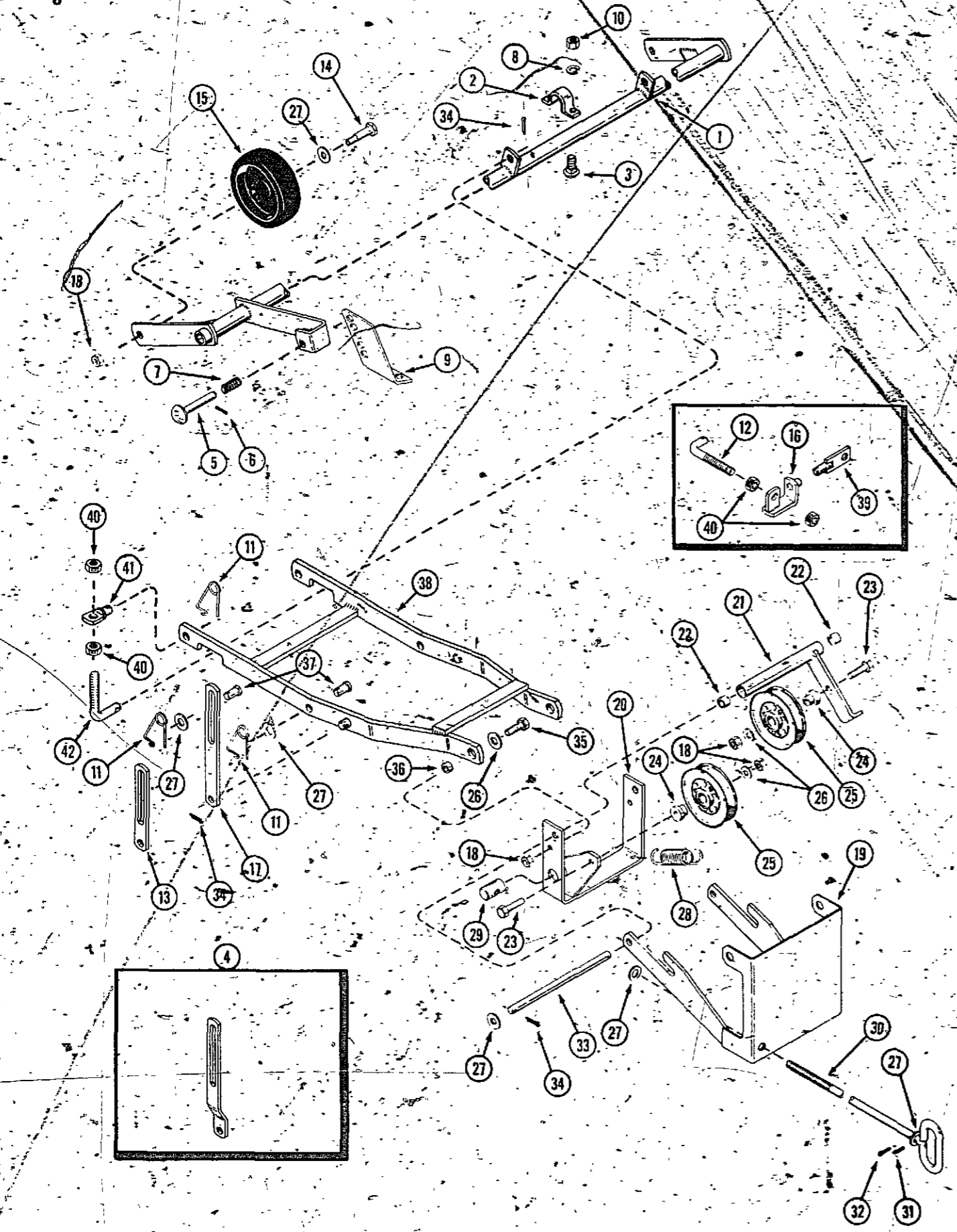

MODEL J45, K45, L45-AND M45 ROTARY MOWERS

AXLE AND MOUNTING BRACKETS

REF	PART NO.	DESCRIPTION	REQ'D
1	C 26048	AXLE - rear (K45, L45, M45)	1
1	C 24708	AXLE - rear (J45)	1
2	C 14932	BRACKET - axle mounting	1
3	111- 101	BOLT - 1/4" - 20 x 5/8" carriage, short neck	2
4	C 19652	LINK - lift (R.H. 446 only) comes with tractor, 9-1/2" (240 mm)	1
4	C 25702	LINK - lift (R.H. 446, 448) comes with tractor, 8-3/4" (220 mm)	1
4	C 27225	LINK - lift, short offset R.H. (226)	1
5	C 20005	PIN - retaining	1
6	138- 96	PIN - roll 3/16" x 1"	1
7	C 10482	SPRING	1
8	192- 19	LOCK WASHER - 3/8"	2
9	C 25408	BRACKET - height adjust	1
10	129- 101	NUT - 1/4" - 20	2
11	C 10898	PIN - retaining, special	6
12	C 17686	BOLT - "J" (J45)	2
13	C 18315	LINK - lift, short (use on Model 210, 220, 222, 224, 644, 646 and 648)	2
13	C 18315	LINK - lift, short L.H. (226)	1
14	C 16745	BOLT - shoulder	2
15	C 26736	WHEEL - gauge 5"	2
16	C 19412	LINK - adjusting (needed for tractors before 1980) (J45)	1
17	C 18338	LINK - lift, long (use on Model 444, 446 and 448), 9-1/2" (240 mm)	2
17	C 25703	LINK - lift, long (use on 444, 446 and 448), 8-3/4" (220 mm)	1
18	131- 1181	NUT - lock 3/8" hex	9
	C 25418	FRAME ASSEMBLY - mower mounting (J45)	1
	C 26107	FRAME ASSEMBLY - mower mounting (K45, L45, M45)	1
19	C 17648	BRACKET - front mounting	1
20	C 16569	BRACKET - idler pulleys	1
21	C 16575	BRACKET AND BUSHING ASSEMBLY	1
22	C 17597	BUSHING - bracket	2
23	113- 209	BOLT - 3/8" x 1-1/2"	2
24	C 12264	BUSHING - idler pulley	2
25	C 25370	PULLEY - idler	2
26	195- 525	WASHER - 3/8"	4
27	195- 533	WASHER - 1/2"	8
28	C 21942	SPRING - tension	1
29	C 14269	NUT - belt tension	1
30	C 26890	SCREW - belt tension	1
31	138- 2073	PIN - roll 3/16" x 1"	1
32	132- 318	PIN - cotter 5/32" x 1"	1
33	C 16574	ROD - pivot	1
34	132- 310	PIN - cotter 1/8" x 1"	6
35	113- 208	BOLT - 3/8" x 1-1/4" hex	2
36	C 16573	SPACER	2
37	C 10821	PIN - clevis 1/2" x 7/8"	4
38	C 16824	FRAME - rear mounting (J45)	1
38	C 26050	FRAME - rear mounting (K45, L45, M45)	1
39	C 17048	LINK - adjusting (J45)	2
40	131- 1182	NUT - lock 1/2" NC hex	4
41	C 26033	LINK - adjusting (K45, L45, M45)	2
42	C 26044	BOLT - "J" (K45, L45, M45)	2

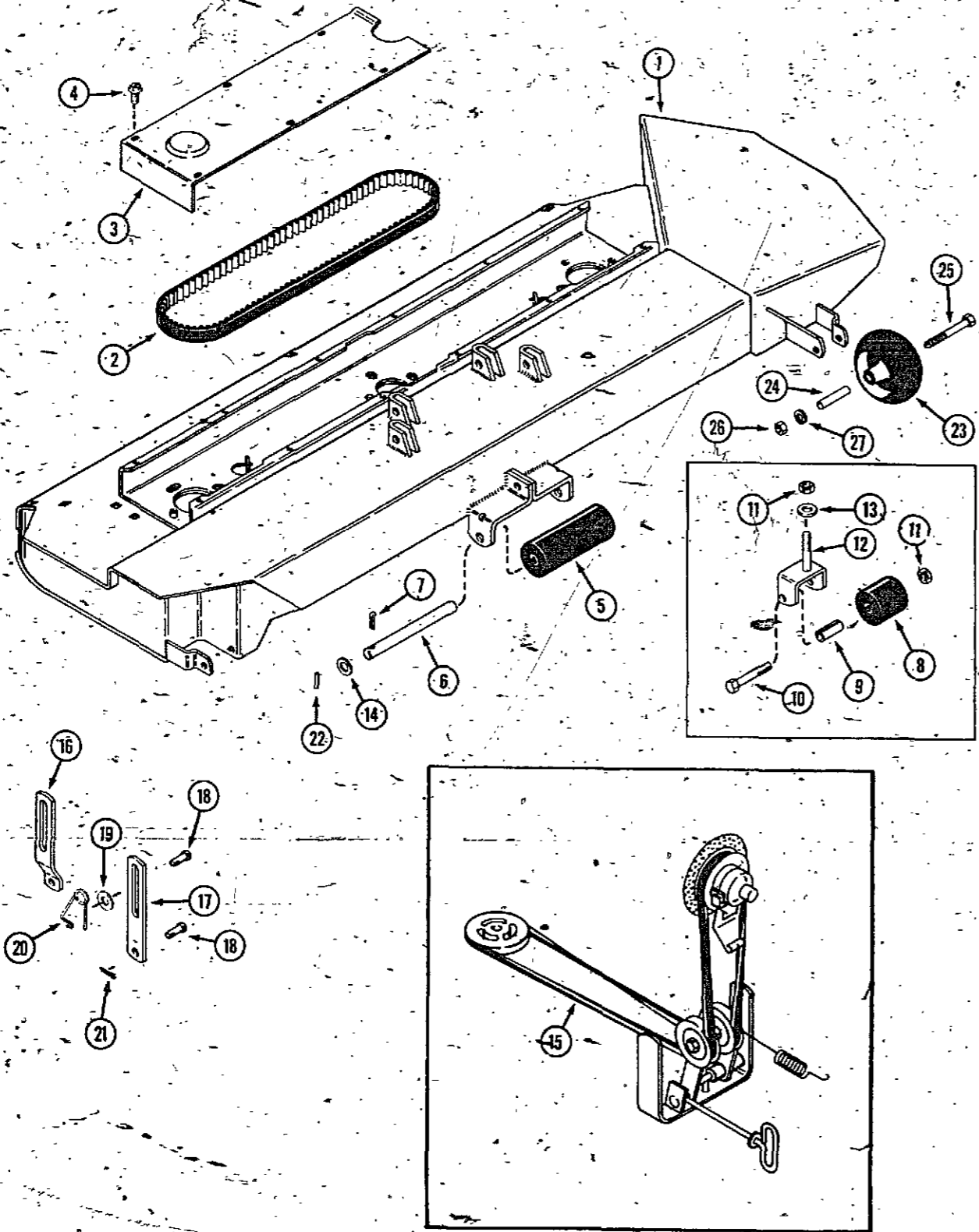

MODEL J48, K48, L48 AND M48 ROTARY MOWERS

CHASSIS, BELTS AND CHASSIS COVERS

REF.	PART. NO.	DESCRIPTION	REQ'D
1	NSS	CHASSIS - mower 60" (1520 mm) (K48, L48) (use G27727 and items 23, 24, 25, 26 and 27)	1
1	C 25611	CHASSIS - mower 60" (1520 mm) (J48)	1
1	C 27727	CHASSIS - mower 60" (1520 mm) (M48)	1
2	C 25687	BELT - spindle drive	2
3	C 25689	GUARD - chassis belt	2
4	187- 1036	SCREW - 1/4" - 20 x 1/2" self-tapping	12
5	A 70524	ROLLER - 2-1/2" x 7" (63.5 x 177.8 mm)	1
6	C 25684	SHAFT - roller (J48)	1
6	C 26405	SHAFT - roller (K48, L48, M48) shown	1
7	132- 310	PIN - cotter 1/8" x 3/4" (3.17 x 25.4 mm) (J48)	2
8	A 70514	ROLLER - 2-1/2" x 2-3/8" (63.5 x 60.32 mm)	4
9	C 25620	SPACER - sleeve (J48, K48, L48)	4
10	113- 427	BOLT - 1/2" - 13 x 3-1/4" hex	4
11	131- 1182	NUT - lock 1/2" hex	6
12	C 25685	CASTER - roller (J48, K48, L48)	2
13	195- 533	WASHER - 1/2"	2
14	195- 541	WASHER - 5/8" (K48, L48, M48)	1
15	C 26653	BELT - "V" mower drive	1
16	C 25690	LINK - mower lift R.H. (J48)	1
17	C 25691	LINK - mower lift L.H. (J48)	1
17	C 26958	LINK - mower lift (K48, L48, M48)	2
18	C 10821	PIN - clevis (quantity 4 on K48, L48, M48)	2
19	195- 533	WASHER - 1/2"	2
20	C 10898	PIN - retaining, special	2
21	132- 310	PIN - cotter	2
22	138- 106	PIN - roll 3/16" x 2-1/2" (K48)	1
23	C 27730	WHEEL - anti-scalp	2
24	C 27731	SPACER - sleeve	2
25	113- 252	BOLT - 3/8" - 16" x 3-3/4"	2
26	129- 103	NUT - 3/8" - 16	2
27	192- 21	LOCK WASHER - 3/8"	2

PULLEYS, BLADES AND SPINDLES

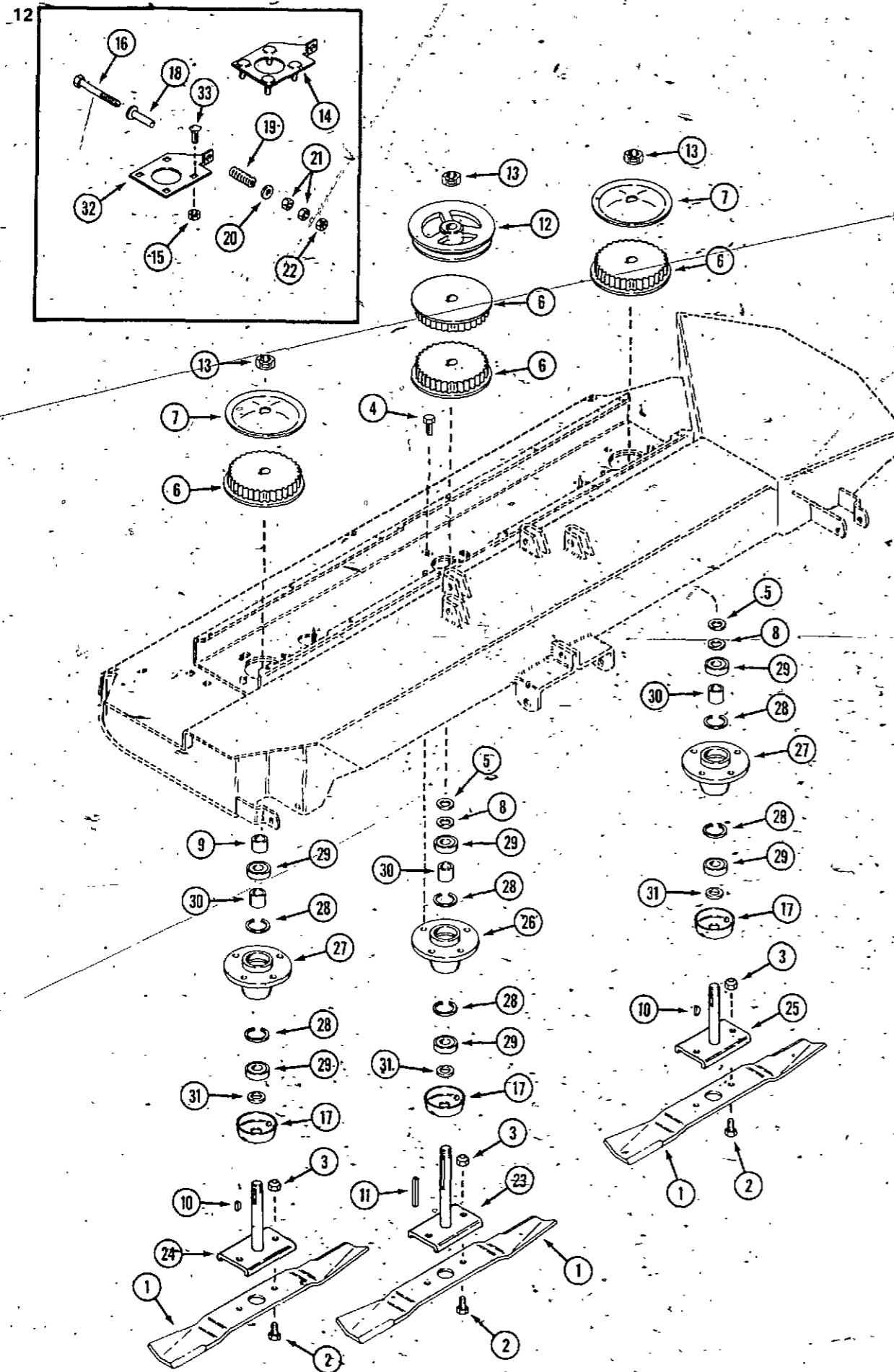

REF.	PART NO.	DESCRIPTION	REQ'D.
1	C 25637	BLADE	3
2	113- 268	BOLT - 3/8" - 16 x 7/8" hex	6
3	131- 1216	NUT - lock 3/8" hex	6
4	113- 206	BOLT - 3/8" - 16 x 3/4" hex	4
5	A 30881	WASHER	2
6	C 25781	SPROCKET - spindle drive	4
7	C 25842	WASHER - belt retaining, special	2
8	A 70282	WASHER	2
9	C 25643	SPACER - spindle	1
10	126- 16	KEY - Woodruff #9 3/16" x 3/4"	2
11	C 25644	KEY - square	1
12	C 25645	PULLEY - drive	1
13	131- 1331	NUT - lock 3/4" hex	3
14	NSS	BRACKET - belt adjusting, chassis (use C25639 and [4] 111-371)	2
15	131- 1216	NUT - lock 3/8" hex	8
16	123- 101	BOLT - 5/16" - 18 x 4" hex	2
17	C 25543	SHIELD - bearing	3
18	C 25829	SPACER - sleeve	2
19	C 25688	SPRING - compression	2
20	195- 520	WASHER - .312" I.D. x .88" O.D.	2
21	129- 102	NUT - 5/16" hex	4
22	131- 176	NUT - lock 5/16" hex	2
23	C 25627	SPINDLE - center	1
24	C 25632	SPINDLE - R.H.	1
25	C 25635	SPINDLE - L.H.	1
26	C 17666	HOUSING - center, spindle	1
27	C 25631	HOUSING - outward, spindle	2
28	C 16516	RING - retaining	6
29	A 70280	BEARING - spindle	6
30	C 10810	SPACER - spindle bearing	3
31	C 25541	SPACER - spindle	3
32	C 25639	BRACKET - belt adjusting, deck	2
33	111- 371	BOLT - 3/8" - 16 x 1" carriage	8

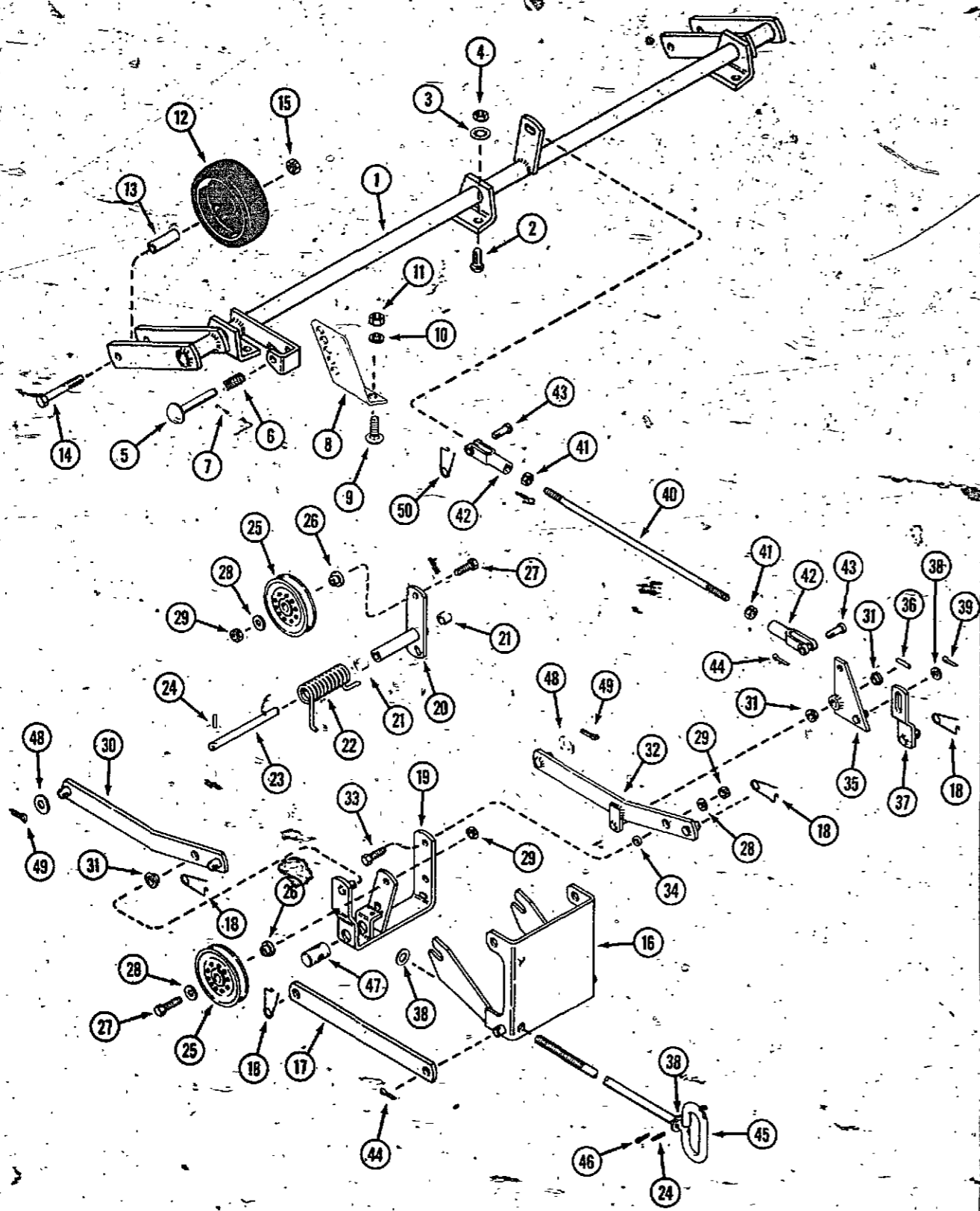

AXLE AND MOUNTING BRACKETS

REF.	PART NO.	DESCRIPTION	REQ'D
1	C 25646	AXLE - rear	1
2	111- 371	BOLT - carriage 3/8" - 16 x 1"	6
3	192- 21	LOCK WASHER - 3/8"	6
4	129- 103	NUT - 3/8" - 16 hex	6
5	C 20005	PIN - locking	1
6	C 10482	SPRING	1
7	138- 96	PIN - roll	1
8	C 15935	BRACKET - height adjusting	1
9	111- 202	BOLT - carriage 5/16" - 18 x 3/4"	2
10	193- 29	LOCK WASHER - 5/16"	2
11	129- 102	NUT - 5/16" - 18	2
12	C 25682	WHEEL - height adjusting	2
13	C 25683	SPACER - sleeve	2
14	113- 447	BOLT - 1/2" - 13 x 3-1/2" hex	2
15	131- 1182	NUT - lock 1/2" - 13 hex	2
16	C 25654	BRACKET - front mounting	1
17	C 25657	LINK - stabilizer	2
18	C 10898	PIN - retaining, special	8
19	C 25659	BRACKET - idler pulleys	1
20	C 25663	ARM AND BEARING ASSEMBLY	1
21	C 17597	BEARING - sleeve	2
22	C 25667	SPRING - torsion	1
23	C 25668	SHAFT - pivot	1
24	138- 319	PIN - roll 3/16" x 1"	1
25	C 25370	PULLEY - idler	2
26	C 12264	BUSHING - shoulder	2
27	113- 209	BOLT - 3/8" - 16 x 1-1/2" hex	2
28	195- 525	WASHER - 3/8"	2
29	131- 933	NUT - lock 3/8" - 16 hex	3
30	C 25669	LINK AND BUSHING ASSEMBLY - suspension R.H.	1
31	C 24182	BUSHING - flange	1
32	C 25672	LINK - suspension L.H.	1
33	113- 208	BOLT - 3/8" - 16 x 1-1/4" hex	1
34	C 16573	SPACER	1
35	C 25675	BELL CRANK AND BUSHING ASSEMBLY - (includes item 31)	1
36	138- 2002	PIN - spiral	1
37	C 25679	LINK - adjusting	1
38	195- 533	WASHER - 1/2"	3
39	132- 310	PIN - cotter 1/8" x 1"	1
40	C 25681	ROD - leveler	1
41	129- 163	NUT - lock 3/8" - 24	2
42	213- 4	CLEVIS - 3/8"	2
43	141- 54	PIN - clevis 3/8"	2
44	132- 321	PIN - cotter	2
45	C 16562	SCREW - idler adjusting	1
46	132- 318	PIN - cotter	1
47	C 14269	NUT - adjusting, special	1
48	195- 541	WASHER - 5/8"	2
49	132- 311	PIN - cotter 5/32" x 1-1/4"	2
50	C 10883	PIN - safety	1

AXLE AND MOUNTING BRACKETS

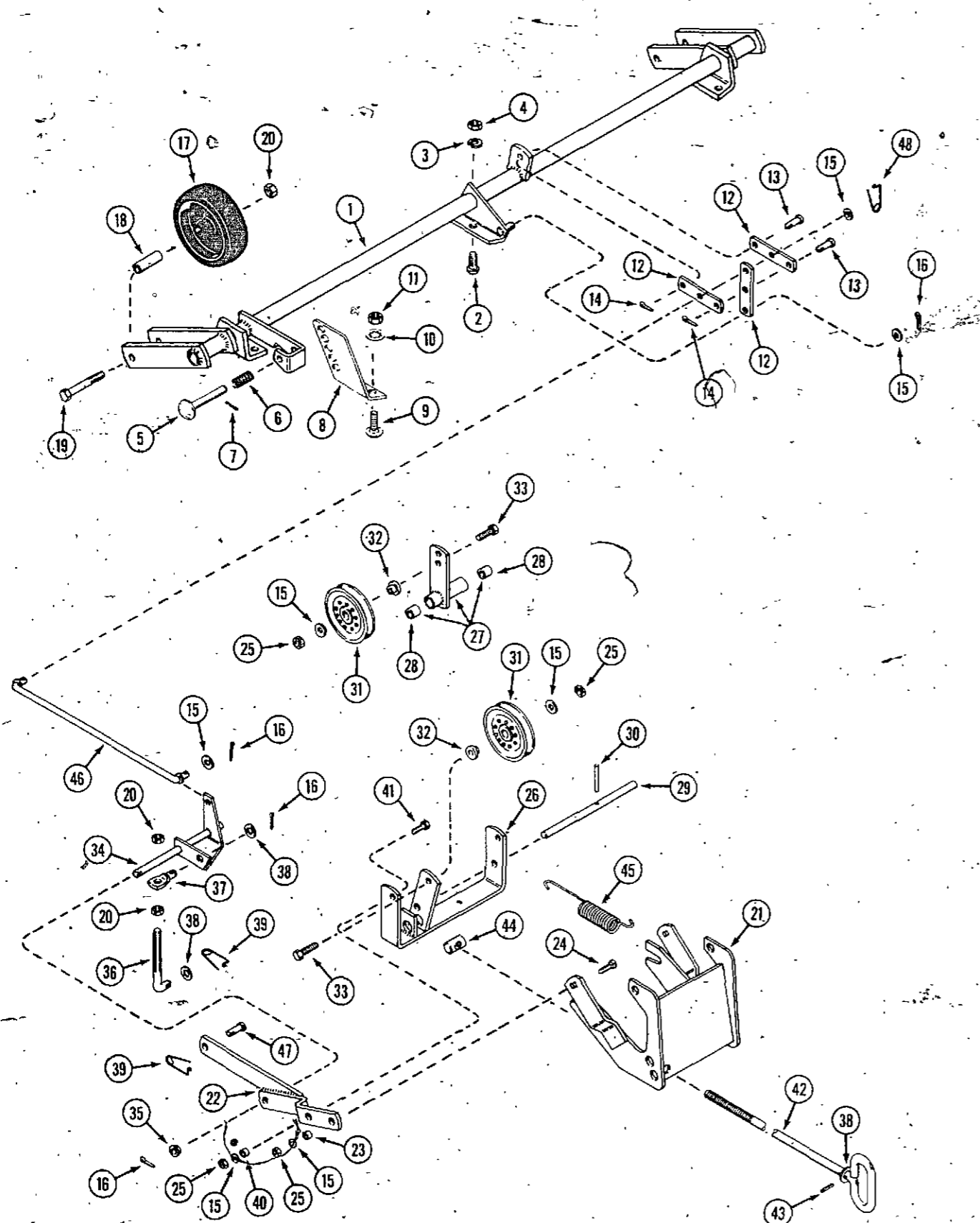

REF.	PART NO.	DESCRIPTION	REQ'D
1	C 26413	AXLE - rear	1
2	111- 371	BOLT - carriage 3/8" - 16 x 1"	6
3	192- 21	LOCK WASHER - 3/8"	6
4	129- 103	NUT - 3/8" - 16 hex	6
5	C 20005	PIN - locking	1
6	G 10482	SPRING - tension	1
7	138- 96	PIN - roll	1
8	C 15935	BRACKET - height adjust	1
9	111- 202	BOLT - carriage 5/16" - 18 x 3/4"	1
10	193- 29	LOCK WASHER - 5/16"	2
11	129- 102	NUT - 5/16" - 18 hex	2
12	C 26384	LINK - rock arm	3
13	141- 4	PIN - clevis 3/8"	2
14	132- 321	PIN - cotter 3/32" x 1"	2
15	195- 525	WASHER - 3/8"	2
16	132- 310	PIN - cotter 1/8" x 1"	9
17	C 25682	WHEEL - height adjust	7
18	C 25683	SPACER - sleeve	2
19	113- 447	BOLT - 1/2" - 13 x 3-1/2"	2
20	131- 1182	NUT - lock 1/2" - 13 hex	2
	C 26408	CARRIAGE ASSEMBLY	4
21	C 26407	BRACKET - front mounting	1
22	C 26403	LINK - tow R.H. (shown)	1
22	C 26402	LINK - tow L.H.	1
23	C 16573	SPACER - sleeve	1
24	111- 366	BOLT - carriage 3/8" - 16 x 1-1/4"	2
25	131- 1181	NUT - lock 3/8" - 16 hex	4
26	C 26398	BRACKET - idler pulleys	1
27	C 26394	ARM - idler pulley	1
28	C 17597	BEARING - sleeve	2
29	C 26390	SHAFT - pivot, pulley arm	1
30	138- 106	PIN - roll 3/16" x 2-1/2"	1
31	C 25370	PULLEY - idler	1
32	C 12264	BUSHING - pulley	2
33	113- 209	BOLT - 3/8" - 16 x 1-1/2" hex	2
34	C 26389	BELL CRANK	1
35	C 12127	BUSHING - nylon, flange	2
36	C 19502	BOLT - "J"	1
37	C 26033	PIN - adjust	1
38	195- 533	WASHER - 1/2"	3
39	C 10898	PIN - safety	3
40	C 16573	SPACER - sleeve	2
41	113- 208	BOLT - 3/8" - 16 x 1-1/4" hex	2
42	C 26890	SCREW - idler adjust	1
43	138- 92	PIN - roll 3/16" x 3/4"	2
44	C 14269	NUT - adjust, special	1
45	C 26386	SPRING - tension	1
46	C 26385	LINK - leveler	1
47	C 10821	PIN - clevis	2
48	C 10883	PIN - safety	1

DECALS (English)

REF.	PART NO.	DESCRIPTION	REQ'D
1	C 21960	DECAL - drive belt (J45, K45, L45, M45)	1
2	C 12519	DECAL - "No Step"	2
4	NSS	DECAL - "Case" (use 321-6379)	1
5	321- 4381	DECAL - spinning blade	1
6	321- 6235	DECAL - drive belt (J48)	1
7	321- 6210	DECAL - cutting height	1
8	321- 6236	DECAL - spindle drive belt (J48, K48, L48, M48)	2
9	321- 6263	DECAL - "Commercial" (J48, K48, L48, M48)	1
10	321- 6379	DECAL - "Case" (early production)	1
11	321- 6668	DECAL - "Flying Debris" (J45, K45, L45, M45)	1
12	C 26423	DECAL - drive belt (K48, L48, M48)	1

DECALS (French and English)

1	321- 4730	DECAL - drive belt (J45, K45, L45, M45)	1
2	321- 4726	DECAL - "No Step"	2
3	321- 4698	DECAL - cutting height (J45, K45, L45, M45)	1
5	321- 4763	DECAL - spinning blade	1
6	321- 6326	DECAL - drive belt (J48)	1
8	321- 6327	DECAL - spindle drive belt (J48, K48, L48, M48)	2
11	321- 6642	DECAL - "Flying Debris" (J45, K45, L45, M45)	1
12	C 26436	DECAL - drive belt (K48, L48, M48)	1

8

CORRECT BLADE ALIGNMENT

BLADE ALIGNMENT AND BELT TENSION

- TIGHTEN THIS NUT AGAINST WASHER AND SPACER
- LOOSEN FOUR SPINDLE HOUSING MOUNTING NUTS ON THE UNDERSIDE OF THE MOWER FOR FREE SLIDING MOVEMENT OF ASS.
- ALIGN BLADES SUCH THAT ADJACENT BLADES ARE PERPENDICULAR TO EACH OTHER AS SHOWN IN BLADE ALIGNMENT DIAGRAM AND BRACKET AS SHOWN
- ADJUST THESE NUTS TO OBTAIN A GAP BETWEEN HEAD OF BOLT AND BRACKET AS SHOWN
- GAP WIDTH TO BE EQUAL TO THICKNESS OF TRACTOR IGNITION KEY. USE KEY AS A GAGE
- TIGHTEN FOUR SPINDLE HOUSING MOUNTING NUTS SECURELY

2

NO STEP

9

COMMERCIAL

6

ATTACHMENT DRIVE CLUTCH PULLEY

DECK DRIVE PULL UP

ISOLER PULLEYS

LEFT SIDE

MANUALLY ENGAGE ATTACHMENT DRIVE

POSTING BELT TO THE PULLEYS AS SHOWN. SECURE THIS BELT MUST BE TIGHTENED TO THE POINT WHERE IT IS JUST TIGHT.

3

CUTTING HEIGHT

1 2 3 2 1

7

CUTTING HEIGHT

H H

M M

L L

1

12

11

WARNING

FLYING DEBRIS
OPERATE MOWER ONLY
WITH DISCHARGE CHUTE
GUARD OR COMPLETE
GRASS CATCHER IN PLACE
DEBRIS MAY CAUSE INJURY

10

CASE

5

DANGER

SPINNING BLADE
KEEP CLEAR
CONTACT CAN INJURE

4

CASE

NUMERICAL INDEX

PART NO.	PAGE NO.	REF. NO.	PART NO.	PAGE NO.	REF. NO.
A	30881	13	C	17666	13
A	70280	7	C	17686	9
A	70280	13	C	18315	9
A	70282	7	C	18338	9
A	70282	13	C	19412	9
A	70514	11	C	19502	17
A	70524	11	C	19652	9
C	10482	9	C	20005	9
C	10482	15	C	20005	15
C	10482	17	C	20005	17
C	10810	7	C	21581	7
C	10810	13	C	21942	9
C	10821	9	C	21960	19
C	10821	11	C	22707	5
C	10821	17	C	23358	5
C	10883	15	C	23359	5
C	10883	17	C	23807	5
C	10898	9	C	23808	5
C	10898	11	C	23810	5
C	10898	15	C	24182	15
C	10898	17	C	24442	7
C	12127	17	C	24708	9
C	12251	7	C	25080	7
C	12264	9	C	25370	9
C	12264	15	C	25370	15
C	12264	17	C	25370	17
C	12519	19	C	25394	5
C	14269	9	C	25402	5
C	14269	15	C	25406	5
C	14269	17	C	25407	5
C	14482	7	C	25408	5
C	14768	7	C	25408	9
C	14932	9	C	25409	5
C	15560	5	C	25541	7
C	15604	7	C	25541	13
C	15615	7	C	25543	7
C	15763	7	C	25543	13
C	15935	15	C	25611	11
C	15935	17	C	25620	11
C	16516	7	C	25627	13
C	16516	13	C	25631	13
C	16562	15	C	25632	13
C	16569	9	C	25635	13
C	16573	9	C	25637	13
C	16573	15	C	25639	13
C	16573	17	C	25642	13
C	16573	17	C	25643	13
C	16574	9	C	25644	13
C	16575	9	C	25645	13
C	16745	9	C	25646	15
C	16824	9	C	25654	15
C	17048	9	C	25657	15
C	17597	9	C	25659	15
C	17597	15	C	25663	15
C	17597	17	C	25667	15
C	17648	9	C	25668	15
C	17666	7	C	25669	15

PART NO.	PAGE NO.	REF. NO.	PART NO.	PAGE NO.	REF. NO.
C	25672	15	C	25672	15
C	25675	15	C	25675	15
C	25679	15	C	25679	15
C	25681	15	C	25681	15
C	25682	15	C	25682	15
C	25682	17	C	25682	17
C	25683	15	C	25683	15
C	25683	17	C	25683	17
C	25684	11	C	25684	11
C	25685	11	C	25685	11
C	25687	11	C	25687	11
C	25688	13	C	25688	13
C	25689	11	C	25689	11
C	25690	11	C	25690	11
C	25691	11	C	25691	11
C	25702	9	C	25702	9
C	25703	9	C	25703	9
C	25781	13	C	25781	13
C	25829	13	C	25829	13
C	26033	9	C	26033	9
C	26033	17	C	26033	17
C	26044	9	C	26044	9
C	26048	9	C	26048	9
C	26050	9	C	26050	9
C	26384	17	C	26384	17
C	26385	17	C	26385	17
C	26386	17	C	26386	17
C	26389	17	C	26389	17
C	26390	17	C	26390	17
C	26394	17	C	26394	17
C	26398	17	C	26398	17
C	26402	17	C	26402	17
C	26403	17	C	26403	17
C	26405	11	C	26405	11
C	26407	17	C	26407	17
C	26408	17	C	26408	17
C	26413	17	C	26413	17
C	26416	11	C	26416	11
C	26423	19	C	26423	19
C	26436	19	C	26436	19
C	26653	11	C	26653	11
C	26736	9	C	26736	9
C	26890	9	C	26890	9
C	26890	17	C	26890	17
C	26958	11	C	26958	11
C	27225	9	C	27225	9
C	27727	11	C	27727	11
C	27730	11	C	27730	11
C	27731	11	C	27731	11

HARDWARE NUMBERS

111-	101	5	16
111-	101	9	3
111-	132	5	12
111-	202	15	9
111-	202	17	9

NUMERICAL INDEX

PART NO.	PAGE NO.	REF. NO.	PART NO.	PAGE NO.	REF. NO.
111-	366	7	111-	366	7
111-	366	17	111-	366	17
111-	371	5	111-	371	5
111-	371	7	111-	371	7
111-	371	13	111-	371	13
111-	371	15	111-	371	15
111-	371	17	111-	371	17
113-	206	7	113-	206	7
113-	206	7	113-	206	7
113-	206	13	113-	206	13
113-	208	9	113-	208	9
113-	208	15	113-	208	15
113-	208	17	113-	208	17
113-	209	9	113-	209	9
113-	209	15	113-	209	15
113-	209	17	113-	209	17
113-	252	11	113-	252	11
113-	268	13	113-	268	13
113-	427	11	113-	427	11
113-	447	15	113-	447	15
113-	447	17	113-	447	17
123-	101	13	123-	101	13
129-	102	5	129-	102	5
129-	103	5	129-	103	5
126-	16	13	126-	16	13
126-	19	7	126-	19	7
129-	101	5	129-	101	5
129-	101	9	129-	101	9
129-	102	13	129-	102	13
129-	102	15	129-	102	15
129-	102	17	129-	102	17
129-	103	11	129-	103	11
129-	103	15	129-	103	15
129-	103	17	129-	103	17
129-	163	15	129-	163	15
131-	176	13	131-	176	13
131-	933	15	131-	933	15
131-	1181	7	131-	1181	7
131-	1181	9	131-	1181	9
131-	1181	17	131-	1181	17
131-	1182	90	131-	1182	90
131-	1182	11	131-	1182	11
131-	1182	15	131-	1182	15
131-	1182	17	131-	1182	17
131-	1216	13	131-	1216	13
131-	1216	13	131-	1216	13
131-	1331	7	131-	1331	7
131-	1331	13	131-	1331	13
132-	310	9	132-	310	9
132-	310	11	132-	310	11
132-	310	11	132-	310	11
132-	310	15	132-	310	15
132-	310	17	132-	310	17
132-	311	15	132-	311	15
132-	318	9	132-	318	9
132-	318	15	132-	318	15
132-	321	15	132-	321	15
132-	321	17	132-	321	17
138-	92	17	138-	92	17
138-	96	9	138-	96	9
138-	96	15	138-	96	15
138-	96	17	138-	96	17
138-	106	11	138-	106	11
138-	106	15	138-	106	15
138-	319	15	138-	319	15
138-	2002	15	138-	2002	15
138-	2073	9	138-	2073	9
141-	4	17	141-	4	17
141-	54	15	141-	54	15
187-	1036	5	187-	1036	5
187-	1036	11	187-	1036	11
192-	19	5	192-	19	5
192-	19	9	192-	19	9
192-	21	5	192-	21	5
192-	21	7	192-	21	7
192-	21	11	192-	21	11
192-	21	15	192-	21	15
192-	21	17	192-	21	17
193-	29	5	193-	29	5
193-	29	15	193-	29	15
193-	29	17	193-	29	17
195-	105	7	195-	105	7
195-	520	13	195-	520	13
195-	525	7	195-	525	7
195-	525	9	195-	525	9
195-	525	15	195-	525	15
195-	525	17	195-	525	17
195-	533	9	195-	533	9
195-	533	11	195-	533	11
195-	533	11	195-	533	11
195-	533	15	195-	533	15
195-	533	17	195-	533	17
195-	541	11	195-	541	11
195-	541	15	195-	541	15
213-	4	15	213-	4	15
321-	4381	19	321-	4381	19
321-	4698	19	321-	4698	19
321-	4726	19	321-	4726	19
321-	4730	19	321-	4730	19
321-	4763	19	321-	4763	19
321-	6210	19	321-	6210	19
321-	6235	19	321-	6235	19
321-	6236	19	321-	6236	19
321-	6263	19	321-	6263	19
321-	6326	19	321-	6326	19
321-	6327	19	321-	6327	19
321-	6379	19	321-	6379	19
321-	6642	19	321-	6642	19
321-	6668	19	321-	6668	19

WING MOWER
2480, 2486
Parts Catalog 8-2950

10-84-RP-1000-100

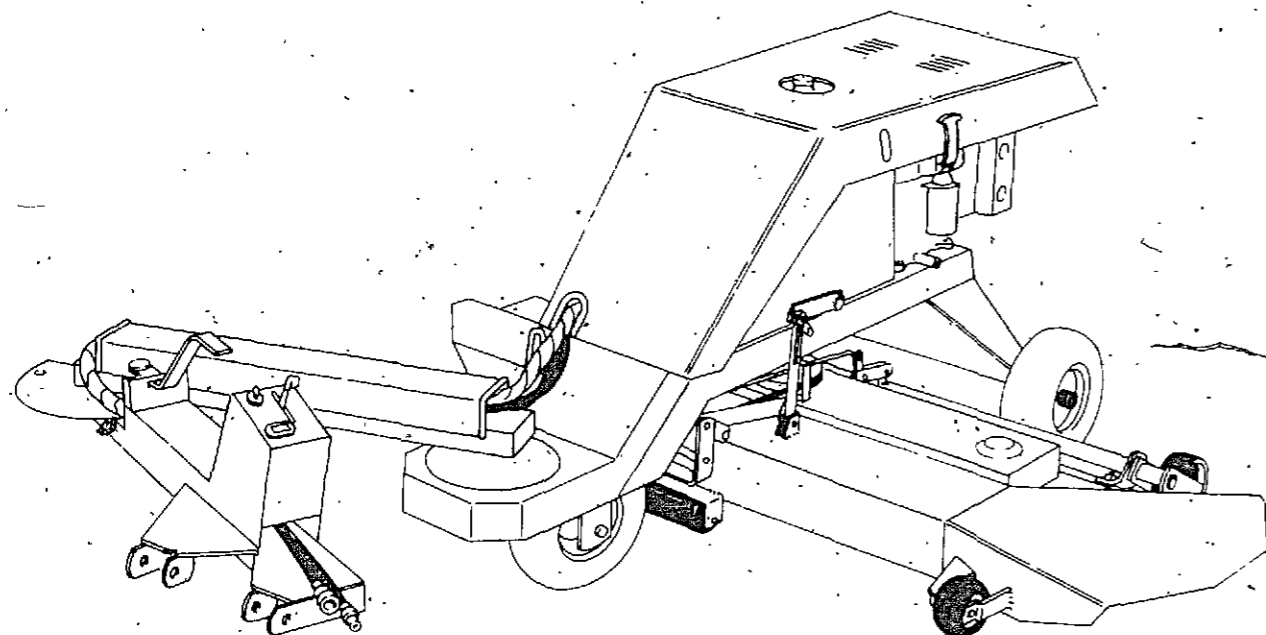

ALPHABETICAL INDEX

ENGINE-SECTION

	PAGE	GRID		PAGE	GRID
Air Baffles	19	D6	Flywheel	9	C10
Air Cleaner	11-15	C12-D15	Fuel Strainer	22	C10
Battery	43	F2	Fuel System	22	C10
Breather, Crankcase	5-19	C6-D6	Gasket Kits	5-7	C6-C8
Camshaft	5-7	C6-C8	Governor	17	D4
Carburetor	11-13	C12-C14	Manifold (2486)	13	C14
Choke Linkage	21	D8	Mqunts, Engine	21	D8
Connecting Rod	5-7	C6-C8	Muffler	15	D2
Counter Weight	9	C10	Oil Pan	5-7	C6-C8
Crankshaft	5-7	C6-C8	Piston	5-7	C6-C8
Cylinder Block	5-7	C6-C8	Spark Plug	9	C10
Cylinder Head	5-7	C6-C8	Starter	41	E14
Electrical System	9	C10	Tank, Fuel	23	D10
Engine Block & Attaching Parts	5-7	C6-C8	Throttle Linkage	21	D8
Exhaust System	15	D2	Trigger, Ignition	9	C10
Filter, Breather	5-19	C6-D6	Valves	5-7	C6-C8

MOWER AND FRAME SECTION

	PAGE	GRID		PAGE	GRID
Axle, Mower	39	E12	Hood	33	E6
Belts	37	E10	Hydraulic Lift	31	E4
Blades	35	E8	Keeper, Belt	25-39	D12-E12
Brackets, Mower Mounting	39	E12	Mower Deck	37	E10
Brake, Belt	37	E10	Mower, Engine Drive	25	D12
Cable, Declutching	31	E4	Pulleys, Idler	39	E12
Caster, Front Wheel	27	D14	Pulleys, Mower	35	E8
Covers, Belt	37	E10	Spindles, Mower	35	E8
Decals	47	F6	Supports and Baffles	23	D10
Electrical System	43-45	F2-F4	Tongue	29	E2
Frame, Main	33	E6	Tower, Instrument	29	E2
Hitch	29	E2	Wheels	27	D14

NOTE: See Grid A2 for -
J, K, L, M45;
J, K, L, M48 Rotary Mowers

INGERSOLL
Ingersoll Equipment Co., Inc.

Technical Publications
119 South First Street
Winneconne, WI 54986-9576

GENERAL INFORMATION

INDEX

There is an index at the front and rear of this catalog.

The front index is an alphabetical index of the major groups or assemblies.

The rear index is a numerical index of the part numbers and pages on which these numbers are shown.

ILLUSTRATION

Each illustration in this catalog shows a group of parts or components. These parts and components are aligned approximately as the parts and components on your machine. Each part and component in an illustration has a reference number. These reference numbers are in a list on the page opposite of the illustration. Next to the reference number is the part number, description and required quantity of the part shown in the illustration.

UAR - "Use as required" indicates that the part quantity is variable.

NSS - "Not sold separately" indicates that the part is only available as a component of an assembly or the part must be purchased locally. If the part is an assembly component, the description will be indented under the assembly description in the parts list.

INDENTED DESCRIPTIONS

An assembly can have many components. The components of an assembly are indicated by an indented description. The quantity for an indented part is the total needed for that complete assembly. See the example.

REF.	PART NO.	DESCRIPTION	REQ'D
	A 55159	CYLINDER ASSY - rear steering	1
28	A 56208	SOCKET ASSY - rear cylinder	1
29	A 55956	PLUG - adjusting, socket assy	1
30	A 55957	SEAT - socket ball	2
31	A 56210	SPRING - socket	1
32	A 56209	SEAT - socket spring	1
33	G 45175	CLAMP ASSY - socket assy	1
	16- 836	BOLT - 1/2" x 2-1/4" N.F. hex	1
34	132- 104	PIN - cotter, 3/16" x 3"	1
35	A 55889	STUD - ball, socket & cylinder	2
36	13- 410	BOLT - 1/4" x 5/8" N.C., hex	4
37	92- 4	LOCK WASHER - 1/4" SAE	4

PARTS ORDERS

All orders must include the following information:

1. Correct part number.
2. Complete description of part or component.
3. Total quantity of each part or component.
4. Product model number.
5. All necessary product identification numbers.
6. Method for sending the parts.
7. Complete and correct address.

CATALOG REVISIONS

As the product changes, we will send you new pages for your catalog.

IMPORTANT: Put all revisions into the catalog as soon as possible.

RIGHT HAND AND LEFT HAND IDENTIFICATION

The words right hand (RH) and left hand (LH) as used in this catalog indicate the direction while you are in the operator's seat in the normal operating position.

PRODUCT IDENTIFICATION NUMBERS

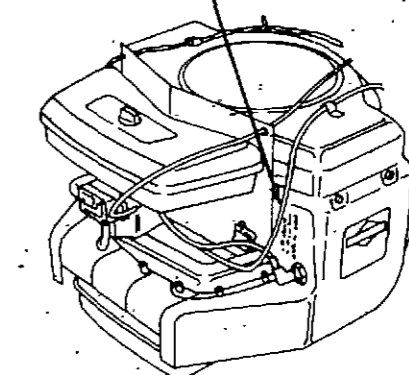
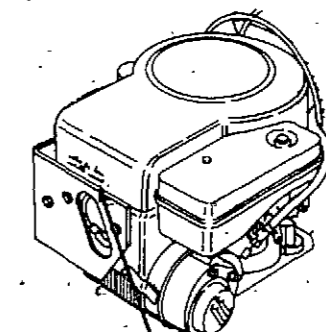
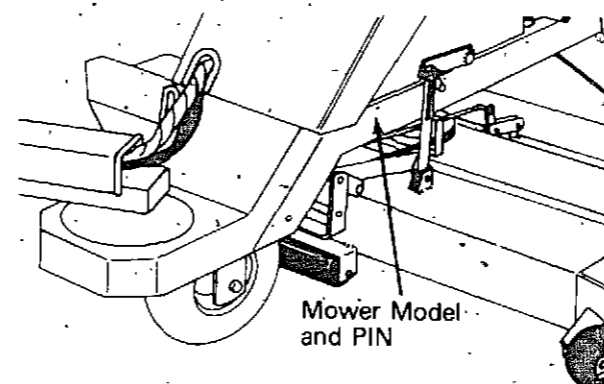

2480

2486

MOWER MODEL	ENGINE MODEL
2480	C26662 SPEC. 190707 - TYPE 5820-01
2486	C26986 SPEC. 402707 - TYPE 0132-06

NOTE: In this catalog are references to Serial Numbers. To order the correct part, use these serial numbers as a guide.

ENGINE BLOCK ASSEMBLY (2480)

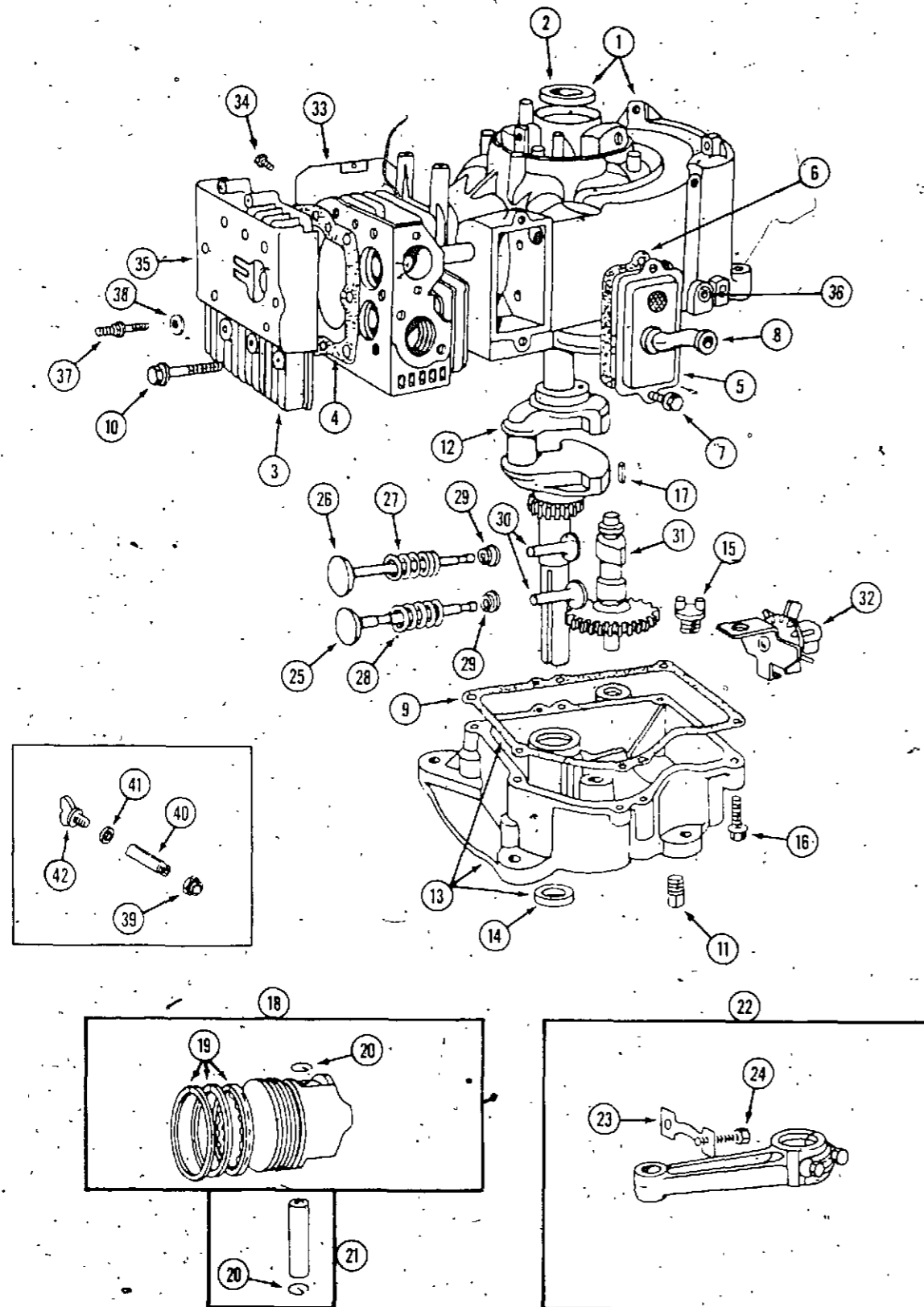

REF.	PART NO.	DESCRIPTION	REQ'D.
1	C 25827	CYLINDER BLOCK ASSEMBLY - short	1
1	NSS	CYLINDER BLOCK ASSEMBLY	1
2	C 25709	SEAL - oil	1
3	C 25710	HEAD - cylinder	1
4	C 25711	GASKET - cylinder head	1
5	BR 391406	BREATHER ASSEMBLY	1
6	BR 27803	GASKET - valve cover	1
7	187- 1508	SCREW - sems	2
8	C 25712	TUBE - breather	1
9	C 25713	GASKET - crankcase cover 1/64" thick	1
9	C 25714	GASKET - crankcase cover .005" thick	1
9	C 25715	GASKET - crankcase cover .009" thick	1
10	BR 93723	SCREW - cylinder head 3" long	6
11	221- 843	PLUG - oil drain	1
12	C 25716	CRANKSHAFT	1
13	C 25717	SUMP - oil (also includes item 9)	1
14	C 25718	SEAL - oil	1
15	BR 66768	PLUG - oil filler	1
16	NSS	SCREW - sump mounting, sems (use 113-120 and 1192-20)	6
17	C 27236	KEY - flywheel	1
18	C 25720	PISTON ASSEMBLY - standard	1
18	C 25721	PISTON ASSEMBLY - .010" oversize	1
18	C 25722	PISTON ASSEMBLY - .020" oversize	1
18	C 25723	PISTON ASSEMBLY - .030" oversize	1
19	C 25724	RING SET - piston, standard	1
19	C 25725	RING SET - piston, .010" oversize	1
19	C 25726	RING SET - piston, .020" oversize	1
19	C 25727	RING SET - piston, .030" oversize	1
20	C 25728	LOCK - piston pin	2
21	C 25729	PIN ASSEMBLY - piston, standard	1
21	C 25730	PIN ASSEMBLY - piston, .005" oversize	1
22	C 25731	ROD ASSEMBLY - connecting	1
23	C 25732	LOCK - connecting rod screw	1
24	C 25733	SCREW - connecting rod	2
25	C 25734	VALVE - exhaust	1
26	C 25735	VALVE - intake	1
27	BR 65906	SPRING - intake valve	1
28	BR 26828	SPRING - exhaust valve	1
29	BR 221596	RETAINER - valve	2
30	C 25736	TAPPET - valve	2
31	C 25737	CAMSHAFT	1
32	C 25746	OIL SLINGER - governor gear and bracket assembly	1
33	C 25751	SHIELD - cylinder	1
34	NSS	SCREW - cylinder shield mounting (use 163-18 and 192-18)	1
35	C 25752	COVER - cylinder head	1
36	BR 231055	BUSHING - governor crank (1/4" I.D.)	1
37	C 27238	STUD - cylinder head	3
38	BR 22963	WASHER	3
	C 25757	GASKET SET - includes items 4, 6, 9 and carburetor mounting gasket)	1
39	221- 86	REDUCER - pipe 3/8" to 1/4"	1
40	C 19473	NIPPLE - pipe, oil drain	1
41	C 14906	GASKET - plug, oil drain	1
42	C 14399	PLUG - pipe, oil drain	1

ENGINE BLOCK ASSEMBLY (2486)

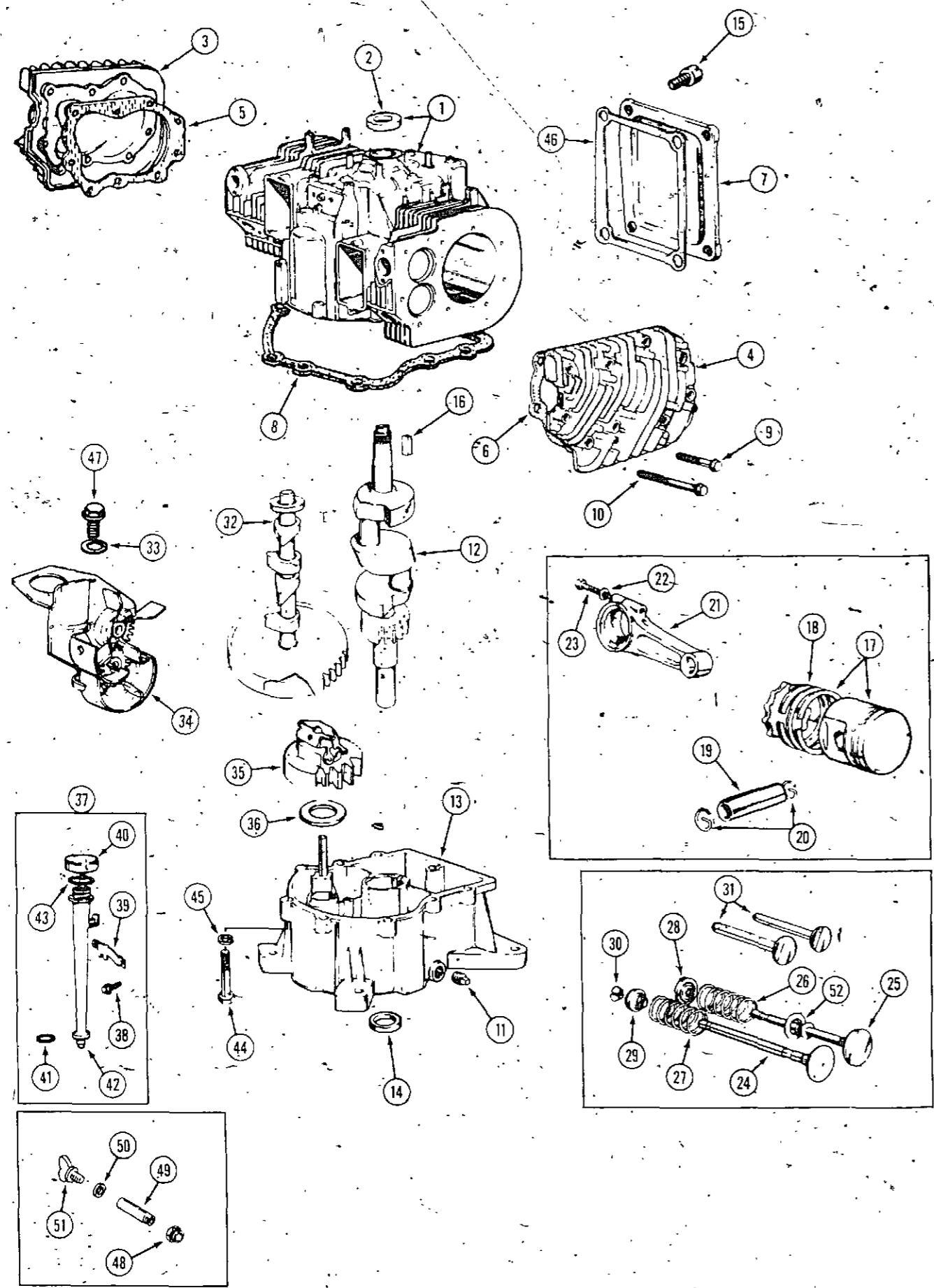

REF.	PART NO.	DESCRIPTION	REQ'D.
1	C 27371	CYLINDER ASSEMBLY	1
2	C 25709	SEAL - oil	1
3	C 27372	HEAD - cylinder R.H.	1
4	C 27373	HEAD - cylinder L.H.	1
5	C 27374	GASKET - cylinder head R.H.	1
6	C 27308	GASKET - cylinder head L.H.	1
7	C 27347	COVER - access	1
8	C 27310	GASKET - crankcase 1/64"	1
8	C 27311	GASKET - crankcase .005"	1
8	C 27312	GASKET - crankcase .009"	1
9	C 27313	BOLT - head 1-15/16"	1
10	BR 93113	BOLT - head 2-5/16"	12
11	221- 843	PLUG - oil drain	6
12	C 27314	CRANKSHAFT	2
13	C 27315	CRANKCASE	1
14	C 25718	SEAL - oil	1
15	NSS	SCREW - cover (use 113-221 and 192-161)	1
16	C 27236	KEY - flywheel	4
17	C 27316	PISTON ASSEMBLY - standard (also includes item 20)	1
17	C 27317	PISTON ASSEMBLY - .010 oversize (also includes item 20)	2
17	C 27318	PISTON ASSEMBLY - .020 oversize (also includes item 20)	2
17	C 27319	PISTON ASSEMBLY - .030 oversize (also includes item 20)	2
18	C 27320	RING SET - piston, standard	2
18	C 27321	RING SET - piston, .010 oversize	2
18	C 27322	RING SET - piston, .020 oversize	2
18	C 27323	RING SET - piston, .030 oversize	2
19	C 25729	PIN ASSEMBLY - piston, standard	2
19	C 25730	PIN ASSEMBLY - piston, .005" oversize	2
20	C 25728	LOCK - piston pin	2
21	C 27324	ROD ASSEMBLY - connecting	2
21	C 27582	ROD ASSEMBLY - connecting .020 undersize	2
22	C 27325	WASHER - 1/4" x 5/8" x 1/32"	2
23	C 25733	BOLT - connecting rod	2
24	BR 390419	VALVE - exhaust	2
25	C 27326	VALVE - intake	2
26	BR 65906	SPRING - intake valve	2
27	BR 26828	SPRING - exhaust valve	2
28	BR 221596	RETAINER - intake valve	2
29	BR 292260	ROTOCOIL - exhaust valve	2
30	BR 93630	RETAINER - valve rotocoil (1 pair)	2
31	C 27327	TAPPET - valve	2
32	C 27328	CAMSHAFT	4
33	192- 18	LOCKWASHER - No. 10 x 1/16" x 3/64"	1
34	C 27329	OIL SLINGER	1
35	C 27330	GEAR - governor	1
36	C 27331	WASHER - thrust	1
37	C 27346	DIPSTICK AND TUBE ASSEMBLY - oil check and fill	1
38	187- 1047	SCREW - No. 8 - 18 x 1/2" round head	1
39	C 27336	CLAMP - oil tube	2
40	C 27337	DIPSTICK - oil	1
41	C 27338	SEAL - oil tube	1
42	C 27339	TUBE - oil filler	1
43	C 27345	SEAL - oil fill cap	1
44	113- 120	BOLT - 5/16" - 18 x 1-3/4"	1
45	192- 20	LOCK WASHER - 5/16"	6
46	C 27342	GASKET - cover	6
47	C 25749	SCREW - No. 10 - 32 x 5/8"	1
48	221- 86	REDUCER - pipe 3/8" to 1/4" oil drain	1
49	C 18814	NIPPLE - pipe, oil drain	1
50	C 14906	GASKET - oil drain	1
51	C 14399	PLUG - oil drain	1
52	C 27583	RETAINER AND SEAL ASSEMBLY - valve	1
	C 27335	GASKET KIT - includes items 5, 6, 8, 48, valve cover gasket, intake manifold gasket and carburetor gasket	1

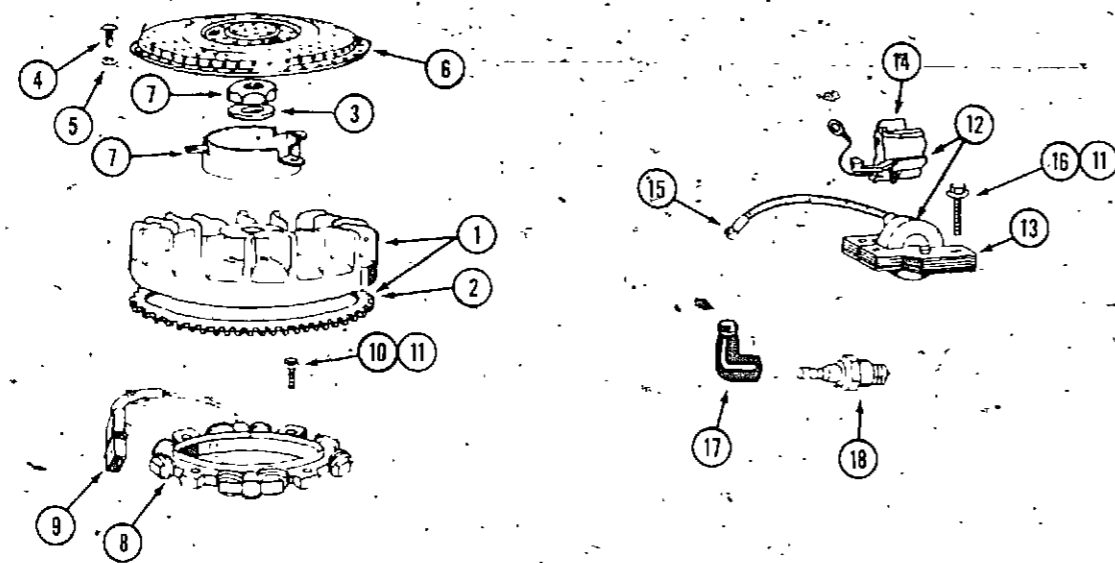

FLYWHEEL AND STATOR

REF.	PART NO.	DESCRIPTION	REQ'D.
1	C 25719	FLYWHEEL AND RING GEAR ASSEMBLY - (2480)	1
1	C 2735J	FLYWHEEL AND RING GEAR ASSEMBLY - (2486)	1
2	BR 392134	RING GEAR - (2480)	1
2	C 27365	RING GEAR - (2486)	1
3	BR 220865	WASHER - spring (2480)	1
3	C 27352	WASHER - spring (2486)	1
4	182- 84	SCREW - No. 8 - 32 x 3/8"	3
5	193- 25	LOCK WASHER - No. 8	3
6	BR 222562	SCREEN - flywheel (2480)	1
6	C 27358	SCREEN - flywheel (2486)	1
7	BR 222561	CUP - screen mounting (2480)	1
7	C 27357	CUP - screen mounting (2486)	1
8	BR 393474	STATOR - alternator	1
9	BR 393456	DIODE AND CONNECTOR ASSEMBLY	1
10	182- 90	SCREW - No. 8 - 32 x 1"	4
11	195- 10	WASHER - No. 8	4
12	C 27253	ARMATURE ASSEMBLY - (2480)	1
12	C 27420	ARMATURE ASSEMBLY - (2486)	1
13	C 27270	ARMATURE - (2480)	1
13	C 27419	ARMATURE - (2486)	1
14	C 27269	TRIGGER - ignition	1
15	BR 221798	TERMINAL - ignition cable	UAR
16	182- 549	SCREW - No. 8 - 32 x 3/4"	2
17	BR 66538	BOOT - spark plug	UAR
18	C 24329	SPARK PLUG - (2480)	1
18	C 27334	SPARK PLUG - (2486)	2

ENGINE COUNTERWEIGHT (2480)

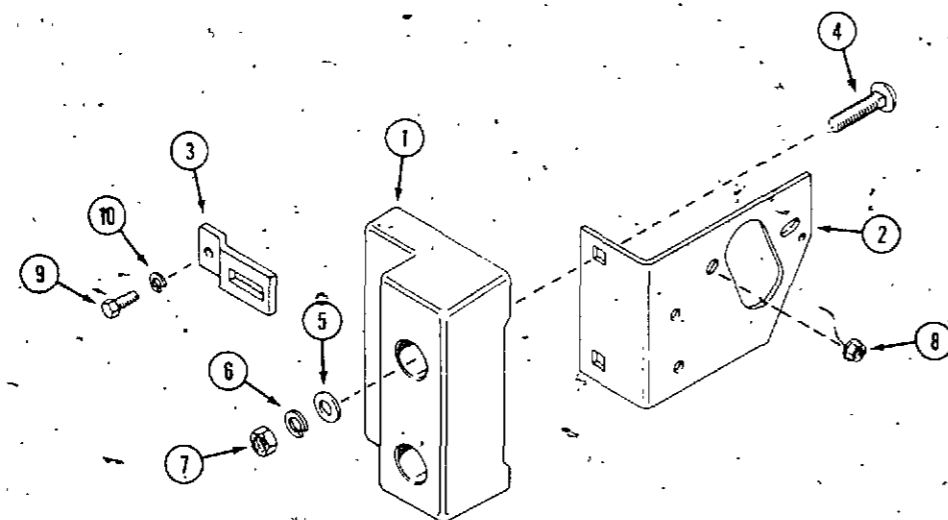

1	C 26197	COUNTERWEIGHT - engine	1
2	C 26198	BRACKET - weight mount	1
3	C 26199	BRACKET - weight mount	1
4	111- 534	BOLT - 1/2" - 13 x 2" carriage	3
5	195- 533	WASHER - 1/2"	3
6	192- 23	LOCK WASHER 1/2"	3
7	129- 105	NUT - 1/2" - 13 hex	3
8	131- 911	NUT - 5/16" - 18 flange lock	3
9	113- 102	BOLT - 5/16" - 18 x 3/4"	1
10	192- 20	LOCK WASHER - 5/16"	1

C25740 CARBURETOR (2480)

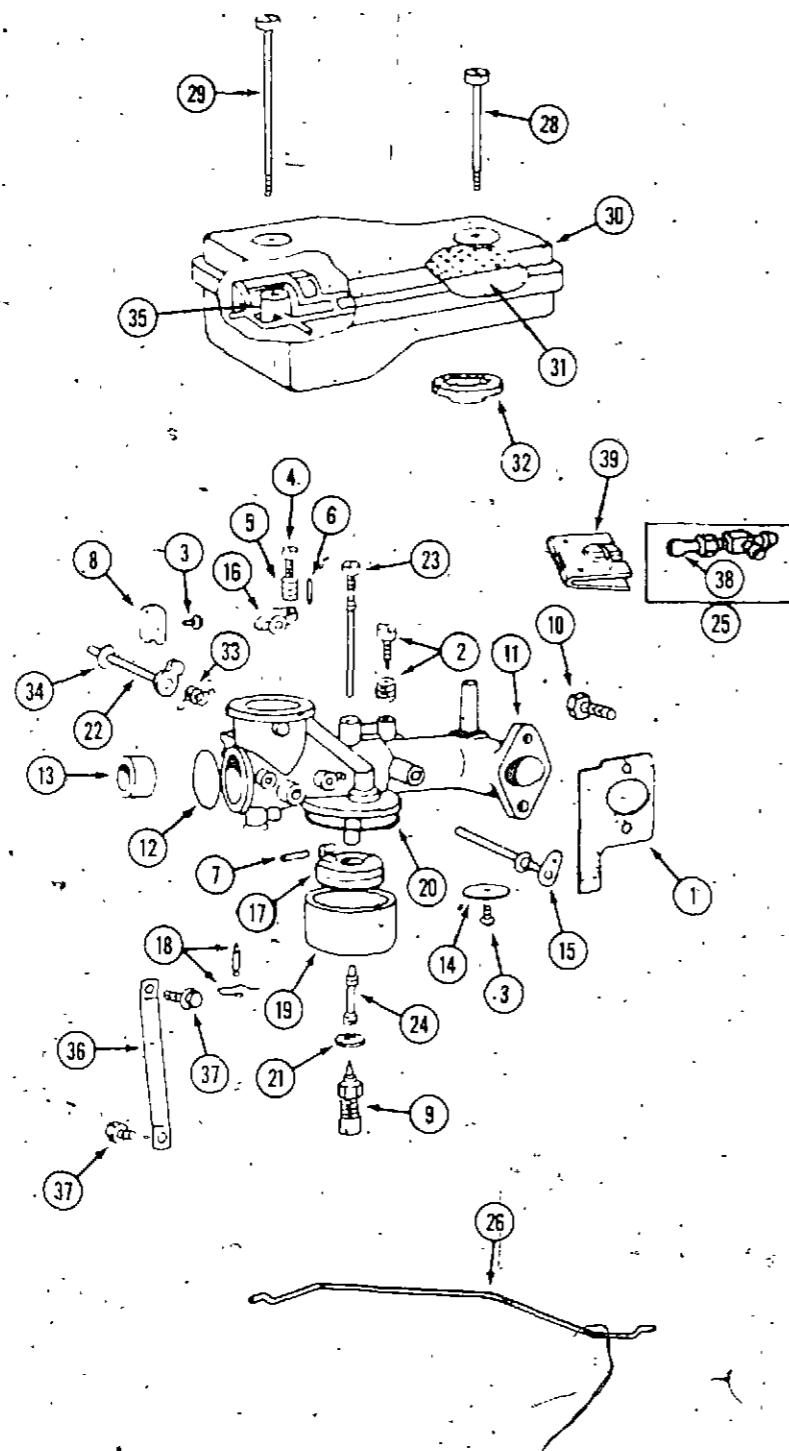

REF.	PART NO.	DESCRIPTION	REQ'D
1	C 25738	GASKET - carburetor mounting	1
2	BR 292681	VALVE ASSEMBLY - carburetor idle	1
3	BR 93499	SCREW - throttle and choke valve mounting, sems	2
4	182- .87	SCREW - machine fillister head 8-32 x 5/8"	1
5	BR 26157	SPRING - throttle adjustment	1
6	138- 251	PIN - throttle stop	1
7	BR 230896	PIN - float hinge	1
8	BR 222010	VALVE - choke	1
9	BR 391233	VALVE - needle	1
10	BR 93357	SCREW - carburetor mounting	2
11	NSS	BODY ASSEMBLY - carburetor (use C25740 carburetor)	1
12	41- 24	PLUG - welch	1
13	C 25742	VENTURI - carburetor	1
14	C 27240	VALVE - throttle	1
15	BR 391512	SHAFT & LEVER - throttle	1
16	BR 211712	STOP - throttle	1
17	BR 299707	FLOAT - carburetor	1
18	BR 299096	VALVE - fuel inlet	1
19	BR 221995	BOWL - float	1
20	BR 270511	GASKET - float bowl	1
21	BR 222014	WASHER - float bowl	1
22	BR 390684	SHAFT & LEVER - choke	1
23	BR 299740	NOZZLE - carburetor	1
24	BR 230932	SCREW - nozzle	1
25	C 27268	CONNECTOR - fuel line	1
26	C 27244	LINK - choke	1
28	BR 93622	SCREW - air cleaner	1
29	C 93323	SCREW - air cleaner	1
30	C 25759	CLEANER ASSEMBLY - air	1
31	C 25758	ELEMENT - air cleaner	1
	C 26358	CUP - air cleaner	1
32	C 25760	GASKET - air cleaner	1
33	BR 261116	SPRING - choke return	1
34	BR 270382	WASHER - choke shaft	1
35	C 25762	SUPPORT - air cleaner element	1
36	C 25764	BRACKET - carburetor	1
37	187- 1510	SCREW	2
38	C 27267	VALVE - fuel shut off	1
39	C 27266	HANDLE - fuel shut off valve	1
	BR 299852	CARBURETOR OVERHAUL KIT - (includes items 2, 7, 9, 12, 18, 20, 21, 23, and 24)	1

CARBURETOR, FUEL PUMP AND MANIFOLD (2486)

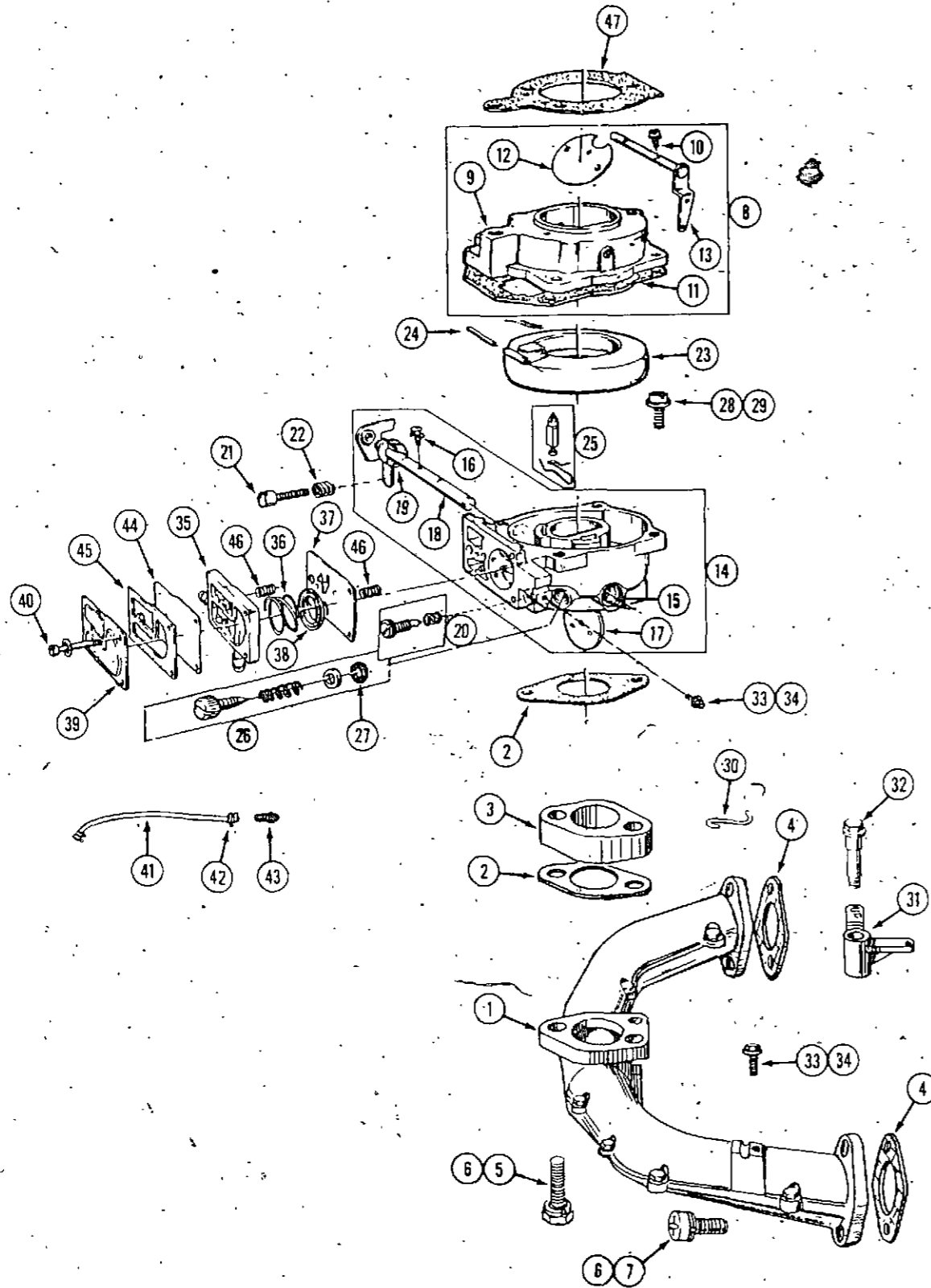

REF.	PART NO.	DESCRIPTION	REQ'D
1	C 27375	MANIFOLD - intake	1
2	C 27376	GASKET - manifold to spacer and carburetor	2
3	C 27377	SPACER - carburetor	1
4	C 27378	GASKET - manifold mounting	2
5	113- 5	BOLT - 1/4" - 20 x 1-1/2"	2
6	192- 19	LOCK WASHER - 1/4"	2
7	182- 205	SCREW - 1/4" - 20 x 7/8"	4
	C 27379	CARBURETOR ASSEMBLY	1
8	C 27380	BODY ASSEMBLY - upper	1
9	C 27381	BODY - upper carburetor	1
10	BR 93499	SCREW - valve	2
11	C 27384	GASKET - body	1
12	BR 222010	VALVE - choke	1
13	C 27387	SHAFT - choke	1
14	C 27386	BODY ASSEMBLY - lower	1
15	C 27382	BUSHING - throttle shaft	1
16	BR 93499	SCREW - valve	2
17	C 27240	VALVE - throttle	1
18	C 27383	SHAFT - throttle	1
19	C 27409	WASHER - throttle	1
20	BR 292681	VALVE ASSEMBLY - idle fuel	1
21	182- 87	SCREW - No. 8 - 32 x 5/8"	1
22	BR 26157	SPRING - throttle adjustment	1
23	C 27385	FLOAT - carburetor	1
24	BR 230896	PIN - float hinge	1
25	BR 299096	VALVE - fuel inlet	1
26	C 27412	VALVE ASSEMBLY - needle	1
27	C 27388	PACKING - needle valve	1
28	163- 4	SCREW - No. 10 - 32 x 5/8"	4
29	192- 18	WASHER - No. 10	4
30	C 27392	LINK - throttle	1
31	C 27393	BELLCRANK	1
32	C 27394	BOLT - shoulder	1
33	177- 97	SCREW - No. 10 - 32 x 1/2"	2
34	195- 513	WASHER - No. 10	2
35	C 27399	BODY - pump	1
36	C 27400	SPRING - pump	1
37	C 27401	DIAPHRAGM	1
38	C 27402	CAP - spring	1
39	C 27403	COVER - fuel pump	1
40	182- 49	SCREW - No. 6 - 32 x 7/8"	3
41	NSS*	HOSE - vacuum, fuel pump 9"	1
42	214- 251	CLAMP - hose	2
43	C 27333	CONNECTOR - fuel pump hose	1
44	C 27413	DIAPHRAGM - damping	1
45	C 27414	GASKET - pump cover	1
46	C 27415	SPRING	2
47	C 27407	GASKET - air cleaner	1
	C 27389	KIT - carburetor overhaul (includes items 11, 19, 20, 24, 25, 26, 27 and fuel pump repair kit)	1
	C 27416	KIT - fuel pump repair (includes items 36, 37, 38, 44, 45 and 46)	1

* Use A21581 bulk 25 ft. Cut to length.

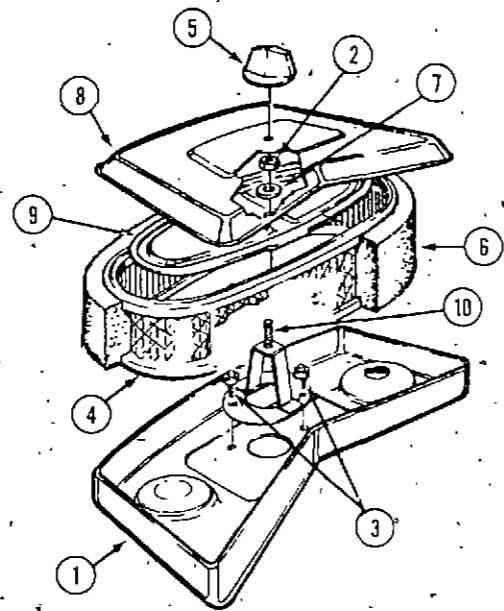

MODEL 2480 AND 2486 WING MOWER

AIR CLEANER (2486)

REF.	PART NO.	DESCRIPTION	REQ'D
1	C 27390	HOUSING - air cleaner	1
2	129- 101	NUT - 1/4" hex	1
3	169- 137	SCREW - No. 10 - 24 x 5/8"	2
4	C 27404	ELEMENT - air cleaner	1
5	C 27405	KNOB - cover, air cleaner	1
6	C 27406	PRECLEANER	1
7	C 27408	WASHER - element plate	1
8	C 27410	COVER - air cleaner	1
9	C 27411	PLATE - element	1
10	C 27417	BRACKET - mounting	1

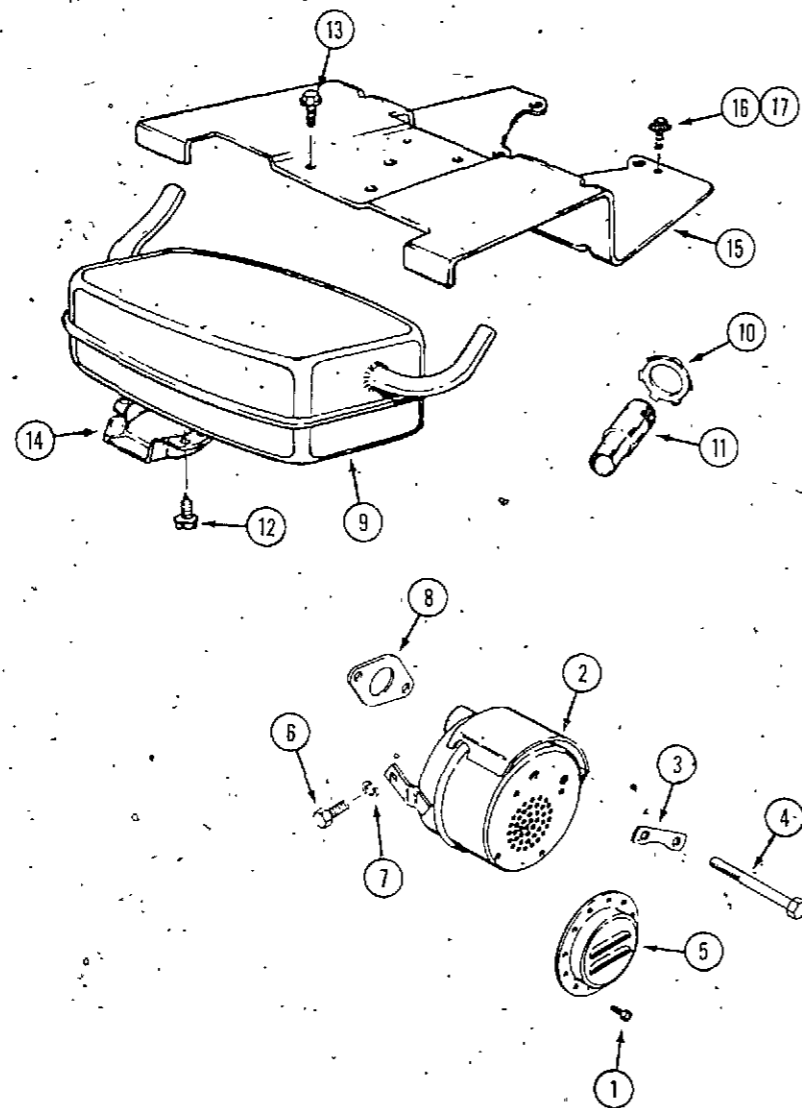

MUFFLER

REF.	PART NO.	DESCRIPTION	REQ'D
1	187- 1041	SCREW - special	8
2	C 25469	MUFFLER - exhaust (2480)	1
3	C 25701	LOCK - bolt (2480)	1
4	113- 138	BOLT - (2480)	2
5	C 25500	DEFLECTOR - exhaust (2480)	1
6	113- 1	BOLT - 1/4" - 20 x 1/2"	1
7	192- 19	LOCK WASHER - 1/4"	1
8	C 26507	GASKET - exhaust (2480)	1
9	C 27353	MUFFLER - exhaust (2486)	1
10	C 27354	NUT - lock, muffler (2486)	2
11	C 27367	CONNECTOR - muffler (2486)	2
12	187- 1041	SCREW - No. 8 - 32 x 3/8"	4
13	113- 2	BOLT - 1/4" - 20 x 5/8"	4
14	C 27364	DEFLECTOR - exhaust (2486)	1
15	C 27366	BRACKET - muffler (2486)	1
16	22- 48	SCREW - 1/4" - 20 x 1/2"	UAR
17	192- 19	LOCK WASHER - 1/4"	UAR

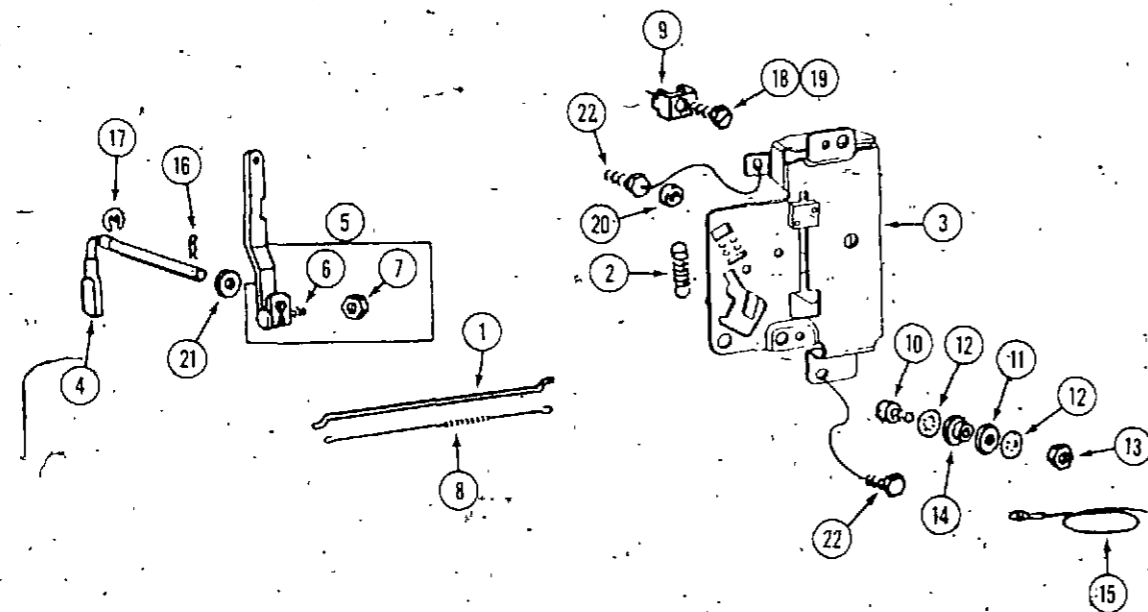

REF.	PART NO.	DESCRIPTION	REQ'D.
1	C 25744	LINK - governor	1
2	BR 261129	SPRING - governor	1
3	C 27257	BRACKET - governor	1
4	BR 231058	CRANK - governor	1
5	BR 391733	LEVER ASSEMBLY	1
6	111- 2	BOLT - lever	1
7	129- 17	NUT - No. 10 - 24	1
8	C 25747	SPRING - governor link	1
9	BR 221535	CLAMP - casing	1
10	182- 87	SCREW - terminal	1
11	BR 66068	WASHER - insulating	1
12	193- 25	LOCK WASHER	2
13	129- 16	NUT - No. 8 - 32	2
14	BR 66554	COLLAR - insulating	1
15	BR 299500	WIRE - ground	1
16	136- 103	PIN - cotter hair pin	1
17	A 27795	RETAINER - "E" ring	1
18	163- 4	SCREW	1
19	192- 18	WASHER	1
20	C 25763	SPACER - mounting	1
21	BR 222450	WASHER - governor crank	1
22	187- 1510	SCREW - mounting	1

GOVERNOR (2486)

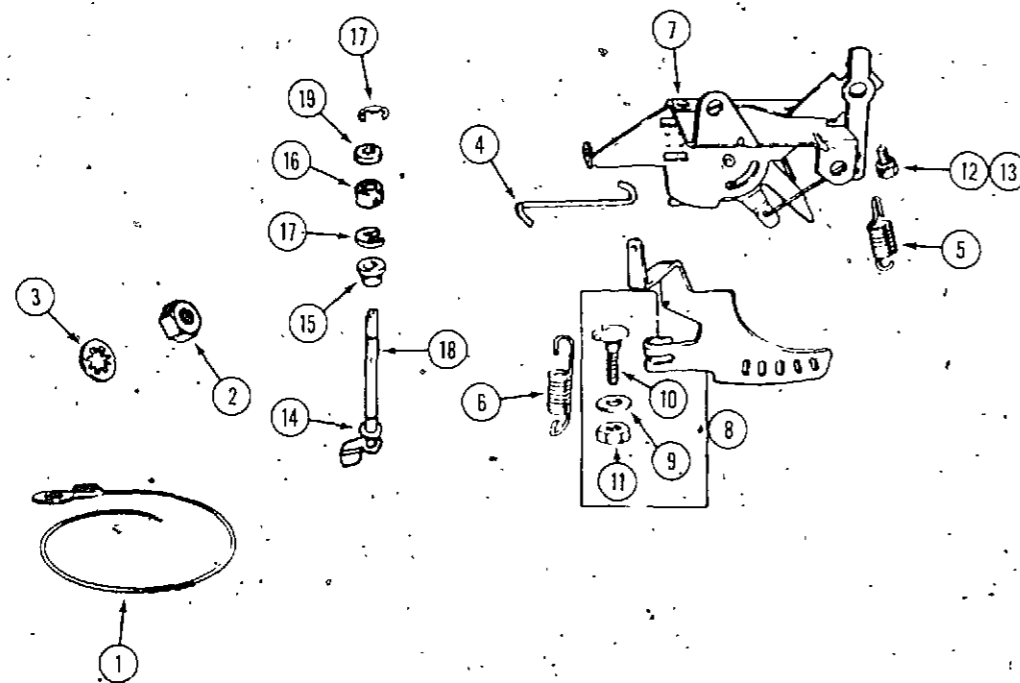

1	BR 299500	WIRE - ground	1
2	129- 16	NUT - No. 8 - 32	1
3	193- 25	LOCK WASHER - No. 8	1
4	C 27391	LINK - governor	1
5	C 27395	SPRING - governor	1
6	C 27396	SPRING - governor idle	1
7	C 27397	BRACKET - governor	1
8	C 27398	LEVER ASSEMBLY - governor	1
9	195- 518	WASHER - 1/4"	1
10	111- 404	BOLT - 1/4" - 20 x 1-1/4"	1
11	129- 101	NUT - 1/4" hex	1
12	22- 48	SCREW - 1/4" - 20 x 1/2"	2
13	192- 19	LOCK WASHER - 1/4"	2
14	C 27332	WASHER - governor crank, inside	1
15	C 27340	BUSHING - governor crank	1
16	C 27341	BUSHING - governor crank	1
17	C 14652	RETAINER - "E" ring	2
18	C 27343	CRANK - governor	1
19	C 27344	SEAL - foam	1

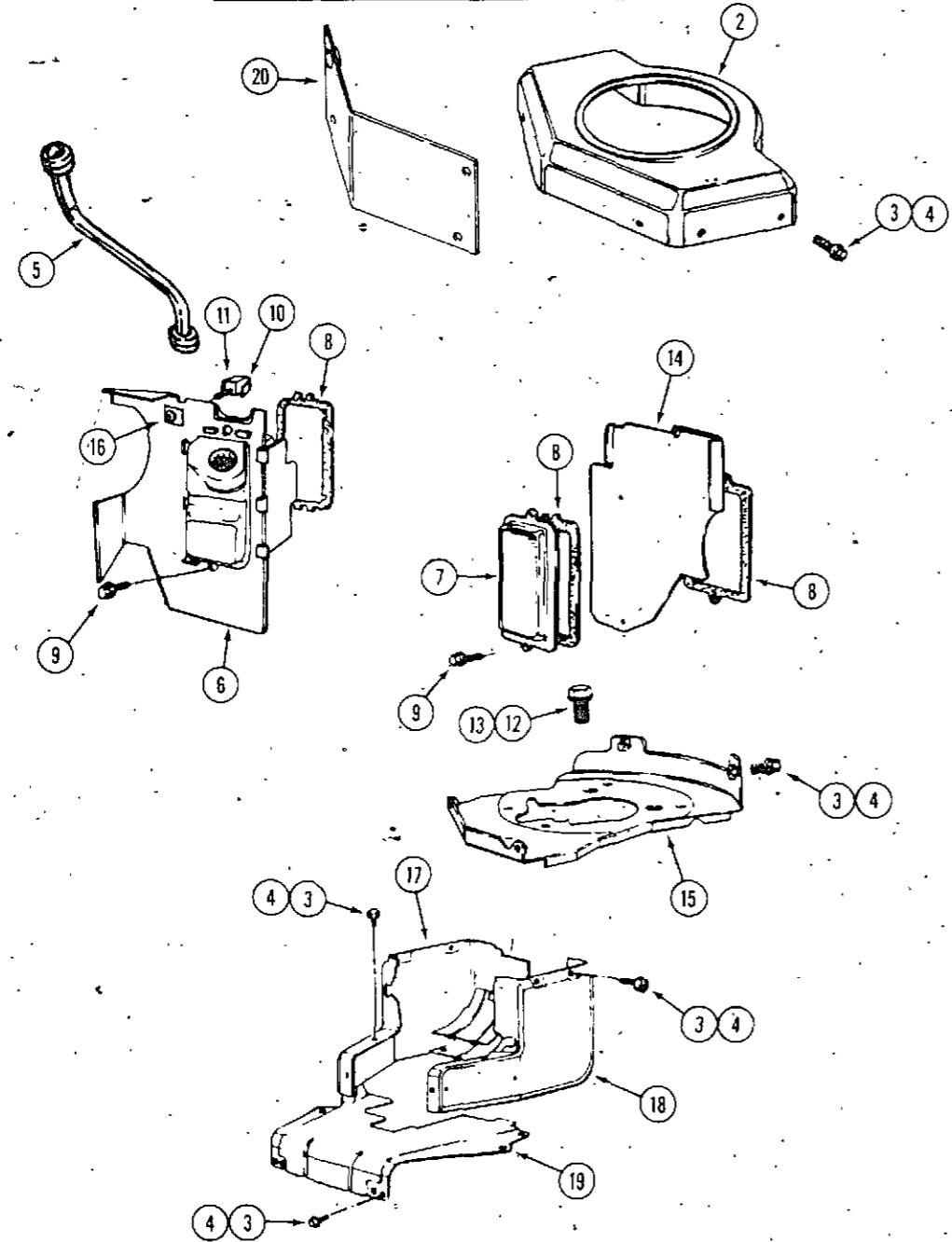
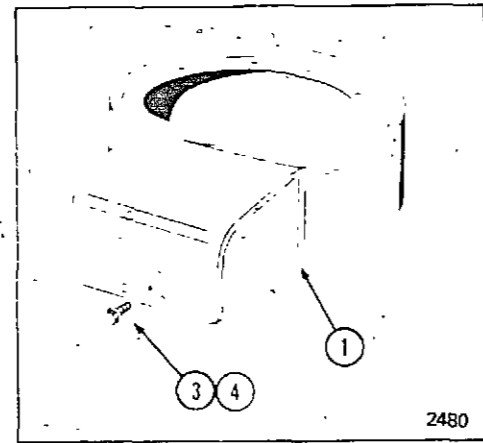

BLOWER HOUSING, ENGINE AIR BAFFLES AND BREATHER COVERS

REF.	PART NO.	DESCRIPTION	REQ'D.
1	C 27273	HOUSING - blower	1
2	C 27355	HOUSING - blower	1
3	22- 48	SCREW - 1/4" - 20 x 1/2"	UAR
4	192- 19	LOCK WASHER - 1/4"	UAR
5	C 27309	TUBE - breather	1
6	C 27348	BREATHER ASSEMBLY - R.H.	1
7	C 27349	COVER - breather L.H.	1
8	C 27350	GASKET - valve cover	2
9	187- 1508	SCREW - No. 10 - 24 x 1/2"	4
10	C 27359	TERMINAL	1
11	C 27360	GROMMET - insulator	1
12	113- 101	BOLT - 5/16" - 18 x 1/2"	4
13	192- 20	WASHER - 5/16"	4
14	C 27362	BAFFLE - L.H. rear, air	1
15	C 27363	PLATE - back	1
16	129- 16	NUT - No. 8 - 32	2
17	C 27368	BAFFLE - cylinder R.H.	1
18	C 27369	BAFFLE - cylinder L.H.	1
19	C 27370	PLATE - top	1
20	C 27059	BAFFLE - engine, front	1

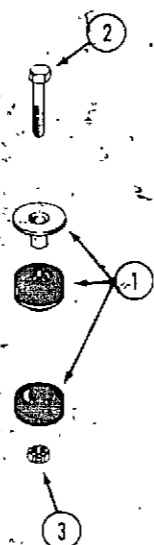

ENGINE MOUNTS

REF.	PART NO.	DESCRIPTION	REQ'D.
1	C 25468	MOUNT - engine (2480 only)	4
2	113- 110	BOLT - 5/16" - 18 x 2-1/4" hex (2480)	4
2	113- 104	BOLT - 5/16" x 1-1/4" (2486)	4
3	131- 176	NUT - 5/16" lock	4

CHOKE AND THROTTLE

1	C 27747	CONTROL - choke (2486)	1
2	C 27637	CONTROL - choke and throttle (2480)	1
3	C 27638	CONTROL - throttle (2486)	1
4	C 12224	HANDLE - throttle (black)	1
5	C 14506	HANDLE - choke (white) 2486	1
6	182- 573	SCREW - No. 10 Phillips	2
7	192- 18	LOCK WASHER - No. 10	2
8	129- 17	NUT - No. 10 - 24	2

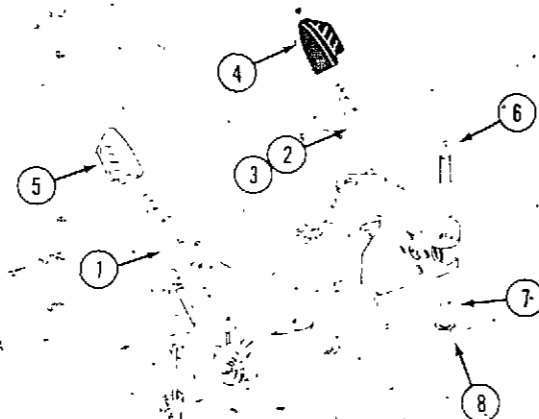

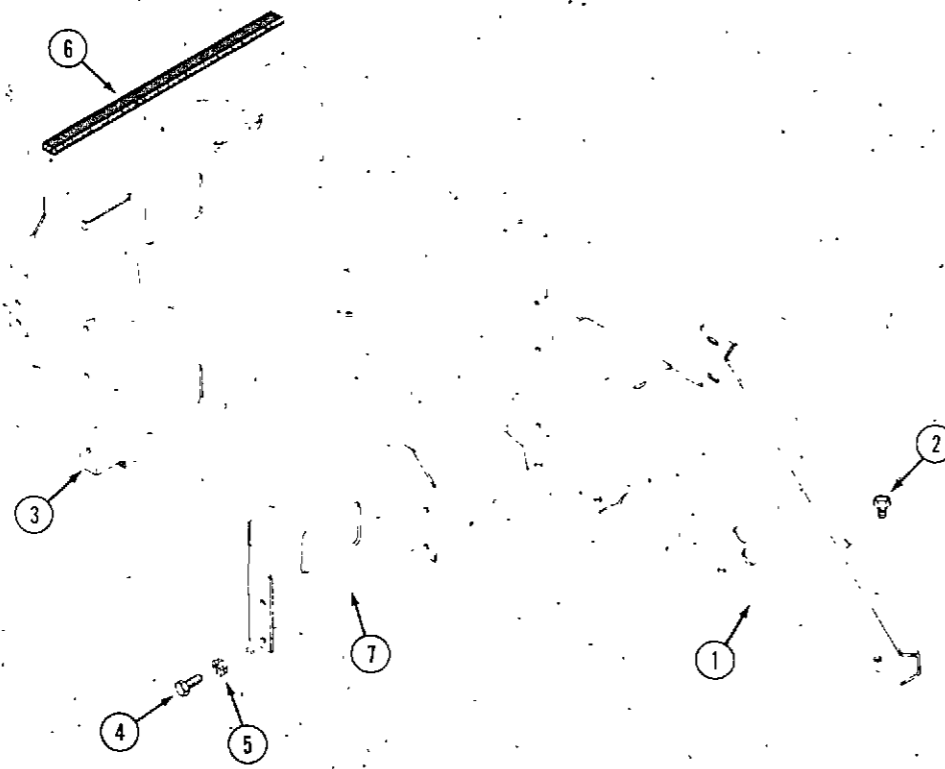
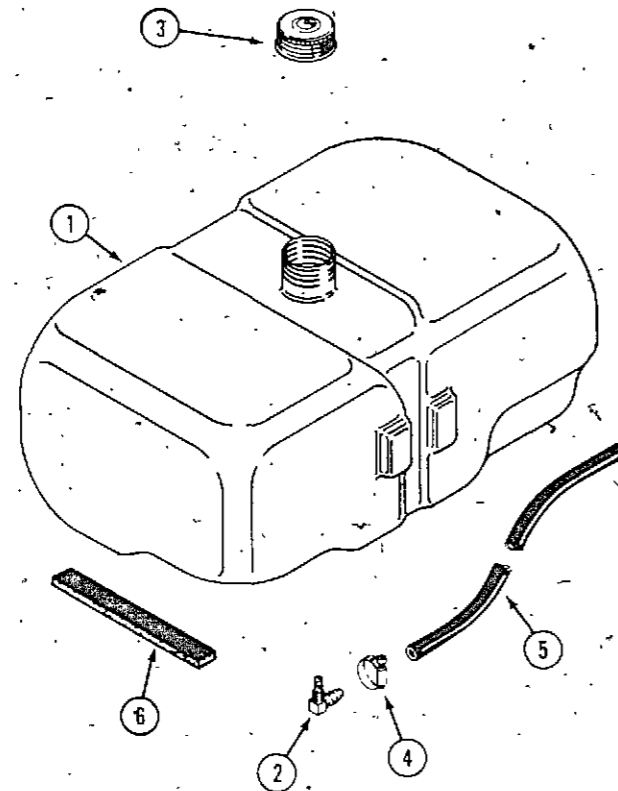

FUEL TANK

REF.	PART NO.	DESCRIPTION	REQ'D.
1	C 26697	TANK - fuel	1
2	C 10657	FITTING - elbow, filter	1
3	C 11529	CAP - fuel tank	1
4	214- 251	CLAMP - hose	2
5	NSS	HOSE - fuel line 24" (610 mm) 2486 (use H400184 cut to length)	1
6	NSS	HOSE - fuel line 19.5" (500 mm) 2480 (use H400184 cut to length)	1
6	NSS	CUSHION - fuel tank 3" (75 mm) use C27703 cut to length	4
6	NSS	CUSHION - fuel tank 8" (200 mm) use C27703 cut to length	1

SUPPORTS AND BAFFLES

1	C 27631	SUPPORT - fuel tank L.H. (shown)	1
1	C 27632	SUPPORT - fuel tank R.H.	1
2	187- 1036	SCREW - 1/4" self-tapping	10
3	C 27633	BAFFLE - rear	1
4	113- 1	BOLT - 1/4" - 20 x 1/2"	10
5	131- 934	NUT - lock 1/4"	10
6	C 27703	CUSHION - liner 17" (430 mm)	3
7	C 27634	BAFFLE - fuel tank	1

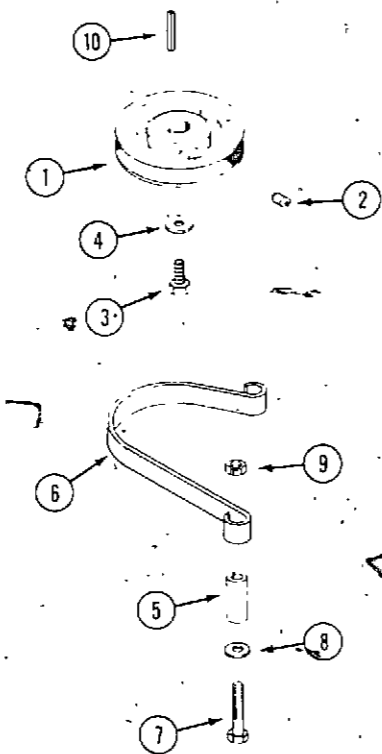

ENGINE PULLEY AND BELT KEEPER

REF.	PART NO.	DESCRIPTION	REQ'D.
1	C 27636	PULLEY - engine crankshaft	1
2	178- 858	SCREW - set 5/16" - 18 x 3/8"	2
3	14- 712	BOLT - 7/16" - 20 x 3/4"	1
4	195- 529	WASHER - 7/16"	1
5	C 26848	SPACER - belt guard	2
6	C 27687	KEEPER - belt	1
7	113- 248	BOLT - 3/8" - 16 x 2-3/4"	2
8	195- 136	WASHER - 3/8" x 1-1/8" x 3/16"	2
9	131- 1181	NUT - lock 3/8"	2
10	T 25070	KEY - square 1/4" x 2"	1

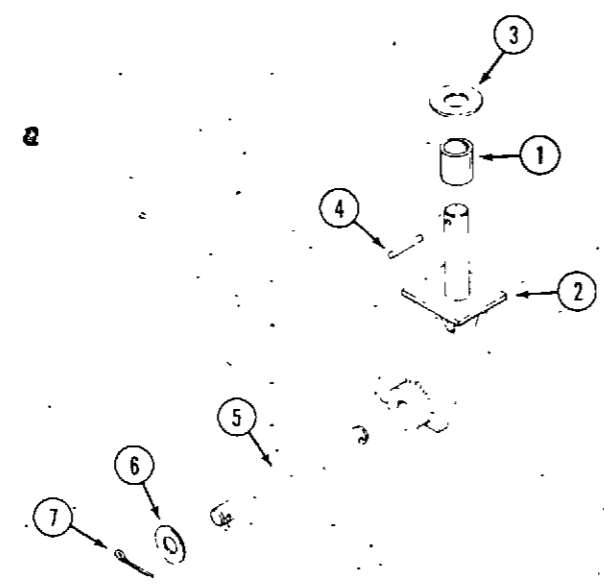

MODEL 2480 AND 2486 WING MOWER

FRONT WHEEL CASTER

REF.	PART NO.	DESCRIPTION	REQ'D.
1	C 13385	BUSHING - sleeve	2
2	C 27981	CASTER - wheel	1
3	C 12718	WASHER - specially hardened	1
4	138- 321	PIN - roll 3/16" x 2"	1
5	C 27977	SHAFT - axle	1
6	A 70282	WASHER	UAR
7	132- 311	PIN - cotter 5/32" x 1-1/4"	2

WHEELS

1	C 24502	WHEEL - front and rear	4
2	C 24503	BUSHING - wheel	8
3	219- 10	FITTING - lubrication 1/4" - 28 taper	4
4	C 26526	CAP - hub, plastic	4
	NSS	TIRE - 11 x 4.00 - 5 Goodyear (order locally)	4

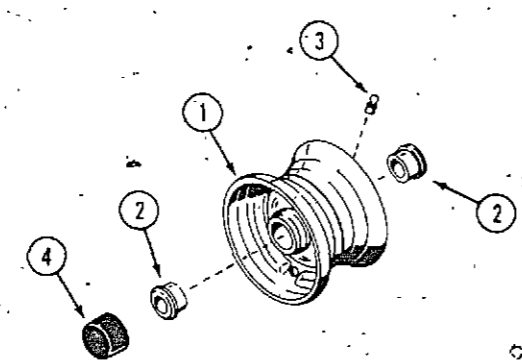

HITCH, TONGUE AND INSTRUMENT TOWER

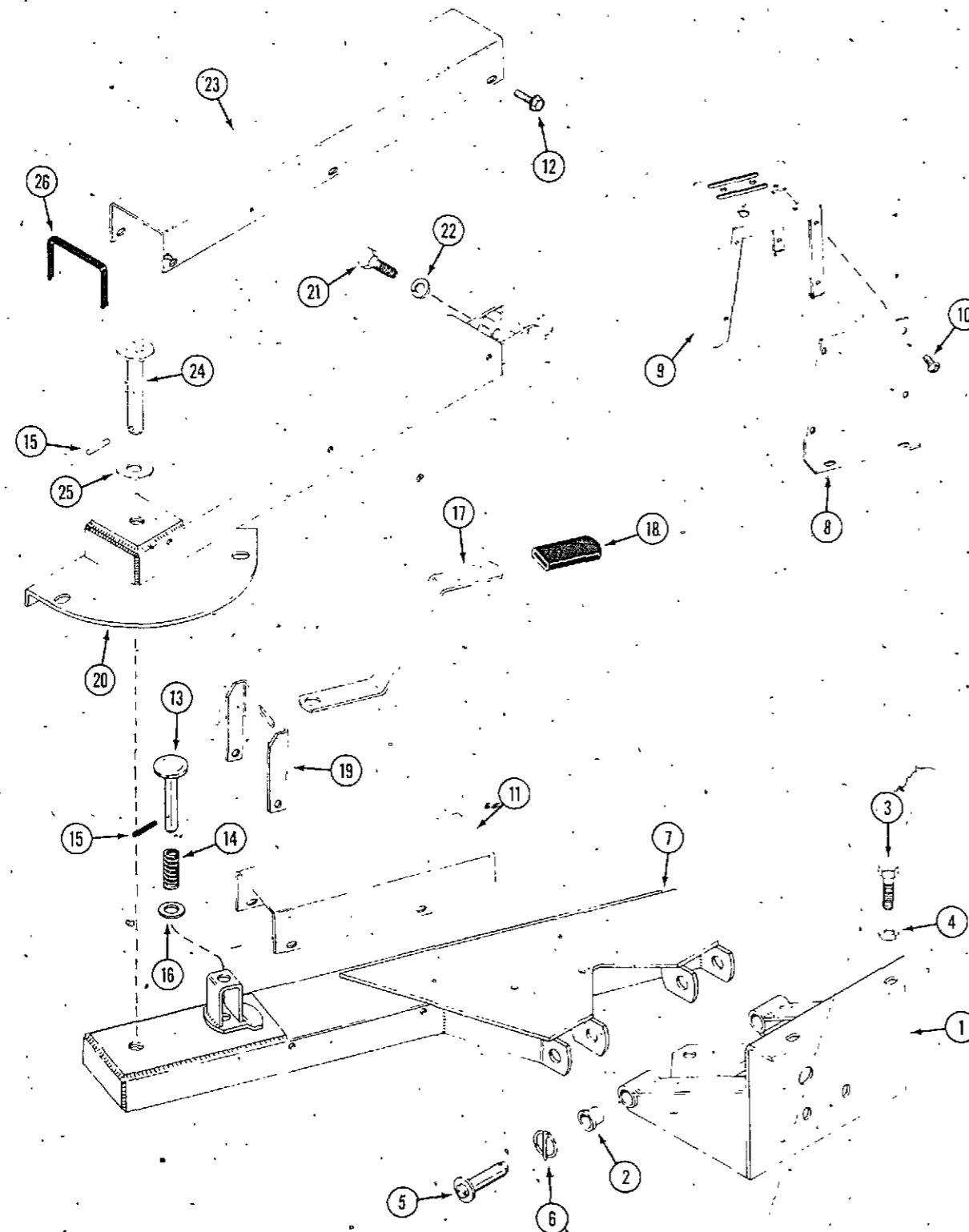

REF.	PART NO.	DESCRIPTION	REQ'D.
1	C 27649	HITCH - tongue	1
2	C 25846	BUSHING - flanged	4
3	113- 426	BOLT - 1/2" x 2-1/2"	1
3	113- 417	BOLT - 1/2" x 1-1/4"	1
4	192- 23	LOCK WASHER - 1/2"	3
5	C 21901	PIN - 3/4" retaining	4
6	A 30338	PIN - klik	2
7	C 27655	TONGUE - front section	2
8	C 27665	COVER - front, tower (shown)	1
8	C 27666	COVER - rear, tower	1
9	C 27667	TOWER - instrument	1
10	187- 1334	SCREW - No. 8 x 1/2" Phillips	8
11	C 27668	COVER - front tongue	1
12	187- 1036	SCREW - 1/4" x 1/2" self-tapping	14
13	C 16373	PIN - latch	1
14	C 24137	SPRING - compression	1
15	138- 2073	PIN - roll 3/16" x 1-1/4"	2
16	195- 2069	WASHER	1
17	C 27669	HANDLE - latch	1
18	C 14728	GRIP - handle	1
19	C 27670	SUPPORT - latch	1
20	C 27671	TONGUE - rear section	1
21	113- 424	BOLT - 1/2" - 13 x 1"	1
22	192- 23	LOCK WASHER - 1/2"	1
23	C 27676	COVER - rear tongue	1
24	C 27677	PIN - pivot	1
25	C 12975	WASHER	1
26	NSS	CHANNEL - liner (use C18153 cut to size)	1

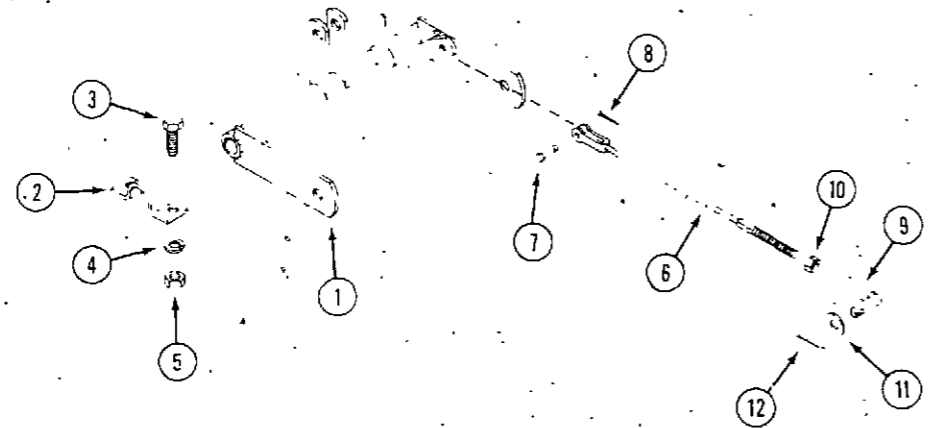

HYDRAULIC LIFT AND DECLUTCHING CABLE

REF.	PART NO.	DESCRIPTION	REQ'D.
1	C 27644	CROSS SHAFT - lift	1
2	C 27646	BRACKET - saddle	2
3	113- 206	BOLT - 3/8" x 3/4"	4
4	192- 21	LOCK WASHER - 3/8"	4
5	129- 103	NUT - 3/8"	4
6	C 27641	CABLE - declutching	1
7	A 67313	PIN - clevis 3/16"	1
8	132- 329	PIN - cotter 1/16" x 3/4"	1
9	C 27620	COUPLING - adjustment	1
10	129- 101	NUT - 1/4"	1
11	195- 525	WASHER - 3/8"	1
12	132- 310	PIN - cotter 1/8" x 1"	1

HYDRAULIC LINES AND CYLINDER

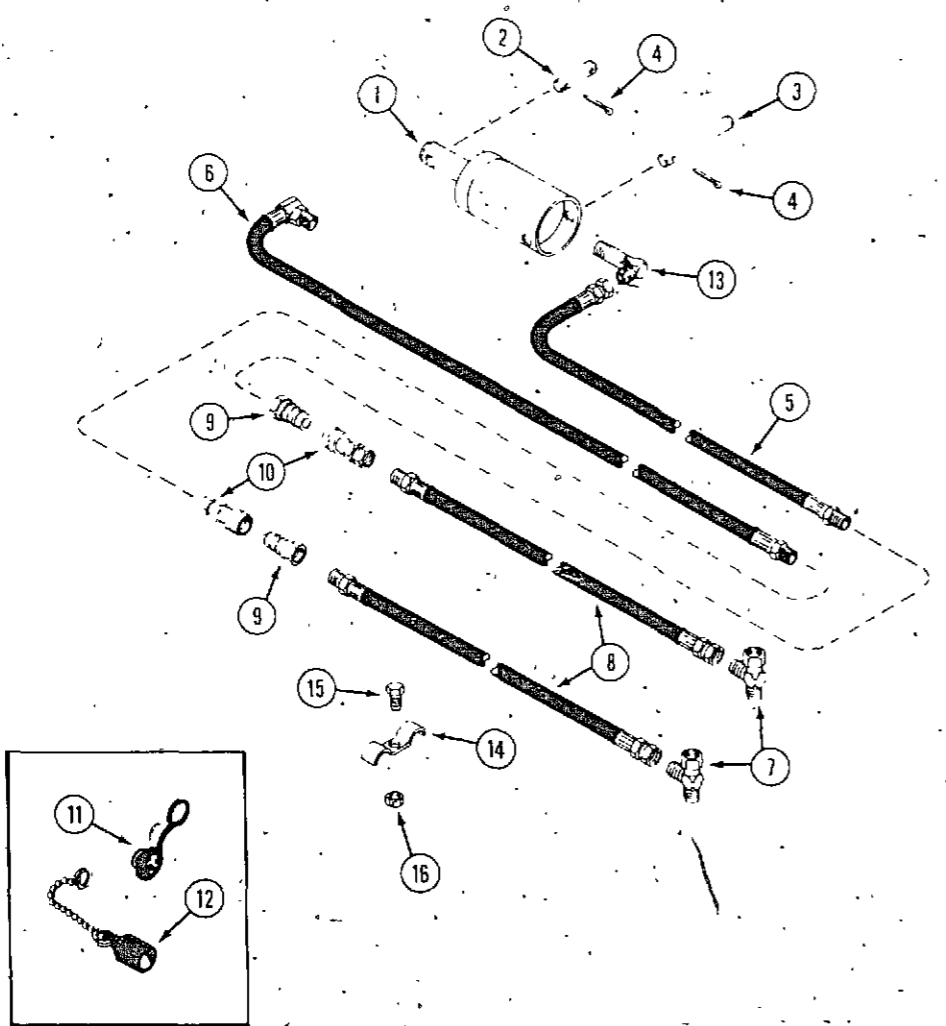

1	C 27814	CYLINDER - lift	1
	C 26495	KIT - seal	1
2	C 18251	PIN - cylinder, rod end	1
3	C 26188	PIN - cylinder, foot end	1
4	132- 310	PIN - cotter 1/8" x 1"	3
5	C 27647	HOSE - cylinder, foot end	1
6	C 27648	HOSE - cylinder, rod end	1
7	218- 5479	FITTING - "TEE" swivel	2
8	C 25369	HOSE - valve	2
9	C 27713	COUPLER - male	2
10	C 27714	COUPLER - female	2
11	C 27715	PLUG - dust, coupler	1
12	C 27716	CAP - dust, coupler	1
13	218- 508	FITTING - cylinder	1
14	C 15389	CLAMP - double tubing	1
15	113- 103	BOLT - 5/16" x 1"	1
16	131- 176	NUT - 5/16" lock	1

HOOD AND FRAME

REF.	PART NO.	DESCRIPTION	REQ'D.
1	C 27611	FRAME - main (2486)	1
1	C 27612	FRAME - main (2480)	1
2	219- 20	FITTING - lubrication 1/4" - 28 taper	1
3	C 27627	HOOD	1
4	C 27775	ROD - hood stop	1
5	132- 378	PIN - cotter 1/16" x 1"	2
6	195- 518	WASHER - 9/32" x 5/8"	2
7	C 16362	PIN - hood hinge	1
8	132- 46	PIN - cotter 1/8" x 3/4"	1
9	NSS	LINER - edge 7-1/2" (use C 18153 cut to length)	1
10	C 27635	LATCH ASSEMBLY	2
11	C 27630	RIVET - 3/16" x 1/8"	4
12	182- 573	SCREW - No. 10 - 24 x 1/2"	4
13	192- 18	LOCK WASHER - No. 10	4
14	129- 17	NUT - No. 10 - 24	4
15	132- 311	PIN - cotter 5/32" x 1-1/4"	2
16	A 70282	WASHER	UAR
17	C 27679	BRACKET - neutral start switch	1
18	111- 101	BOLT - carriage 1/4" x 5/8"	1
19	131- 934	NUT - 1/4" flange lock	1

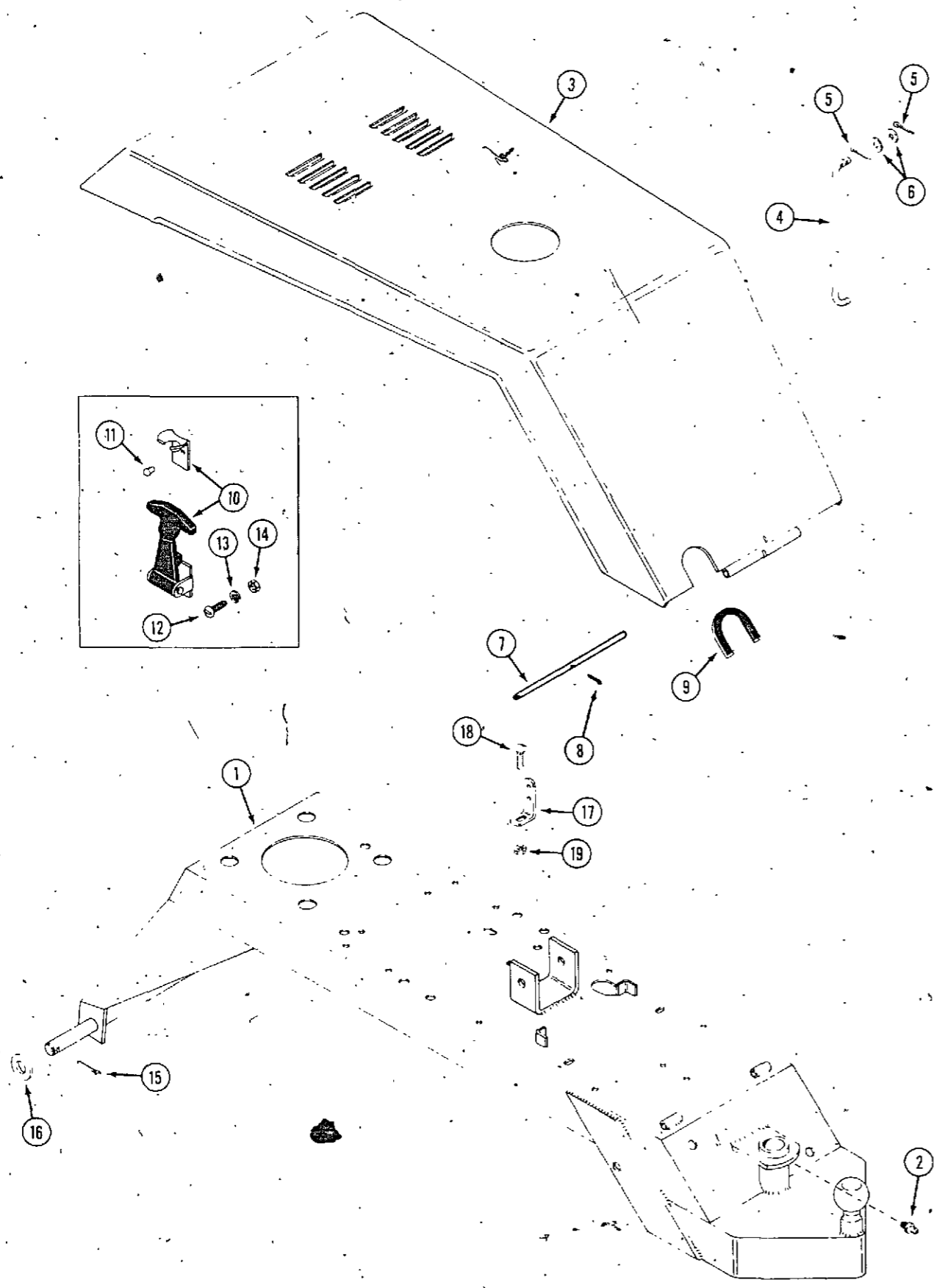

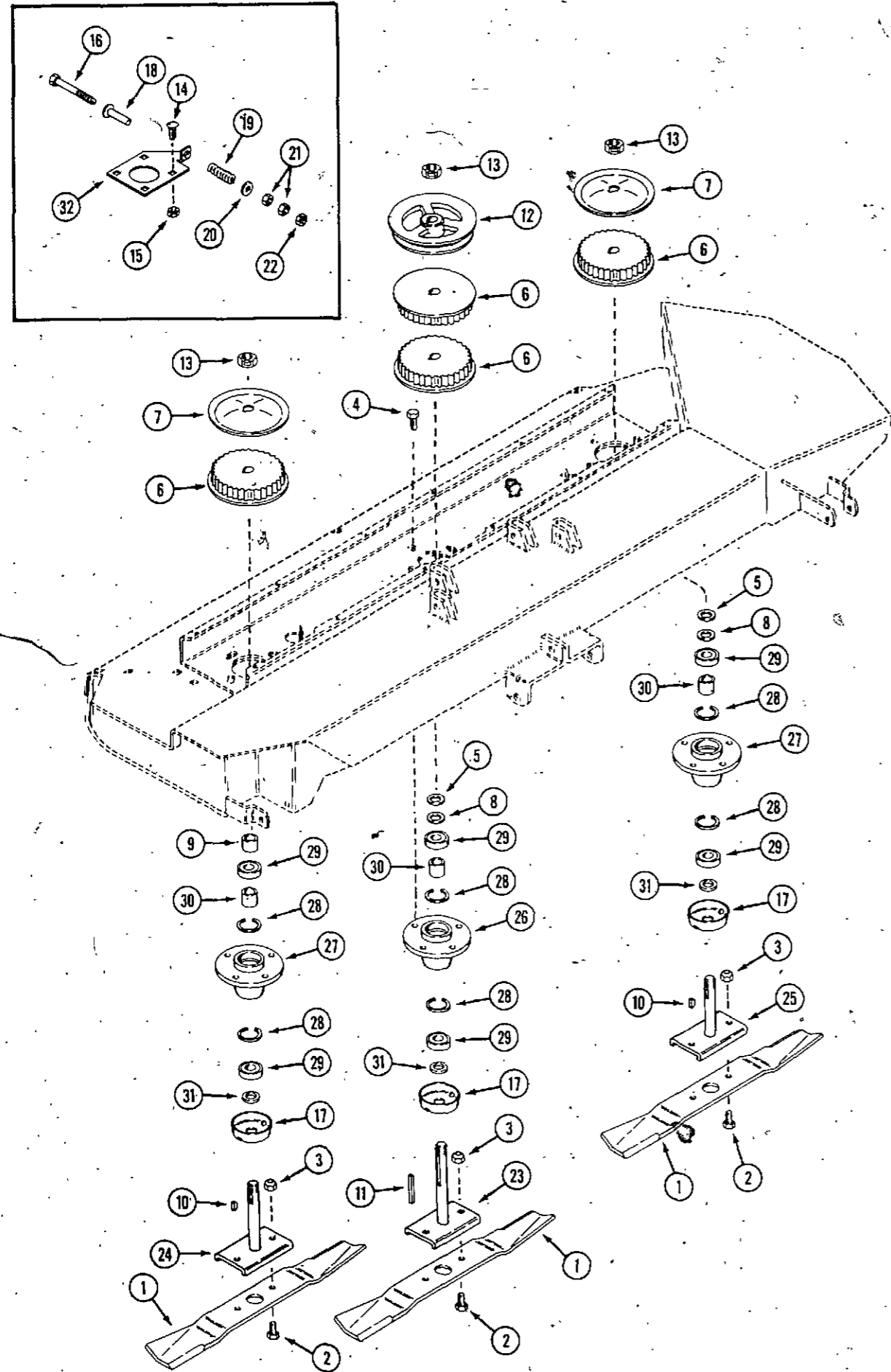

PULLEYS, BLADES AND SPINDLES

REF.	PART NO.	DESCRIPTION	REQ'D.
1	C 25637	BLADE	3
2	113- 268	BOLT - 3/8" - 16 x 7/8" hex	6
3	131- 1216	NUT - lock 3/8" hex	6
4	113- 206	BOLT - 3/8" - 16 x 3/4" hex	4
5	A 30881	WASHER	2
6	C 25781	SPROCKET - spindle drive	4
7	C 25642	WASHER - belt retaining, special	2
8	A 70282	WASHER	2
9	C 25643	SPACER - spindle	1
10	126- 16	KEY - Woodruff #9 3/16" x 3/4"	2
11	C 25644	PULLEY - drive	1
12	C 25645	PULLEY - drive	1
13	131- 1331	NUT - lock 3/4" hex	3
14	111- 371	BOLT - 3/8" - 16 x 1" carriage	8
15	131- 666	NUT - lock 3/8"	8
16	123- 101	BOLT - 5/16" - 18 x 4" hex	2
17	C 25543	SHIELD - bearing	3
18	C 25829	SPACER - sleeve	2
19	C 25688	SPRING - compression	2
20	195- 521	WASHER - 5/16"	2
21	129- 102	NUT - 5/16" hex	4
22	131- 176	NUT - lock 5/16" hex	2
23	C 25627	SPINDLE - center	1
24	C 25632	SPINDLE - R.H.	1
25	C 25635	SPINDLE - L.H.	1
26	C 17666	HOUSING - center, spindle	1
27	C 25631	HOUSING - outward, spindle	2
28	C 16516	RING - retaining	6
29	A 70280	BEARING - spindle	6
30	C 10810	SPACER - spindle bearing	3
31	C 25541	SPACER - spindle	3
32	C 25639	BRACKET - belt adjusting, deck	2

MODEL 2480 AND 2486 WING MOWER

DECK, BELTS AND BELT COVERS

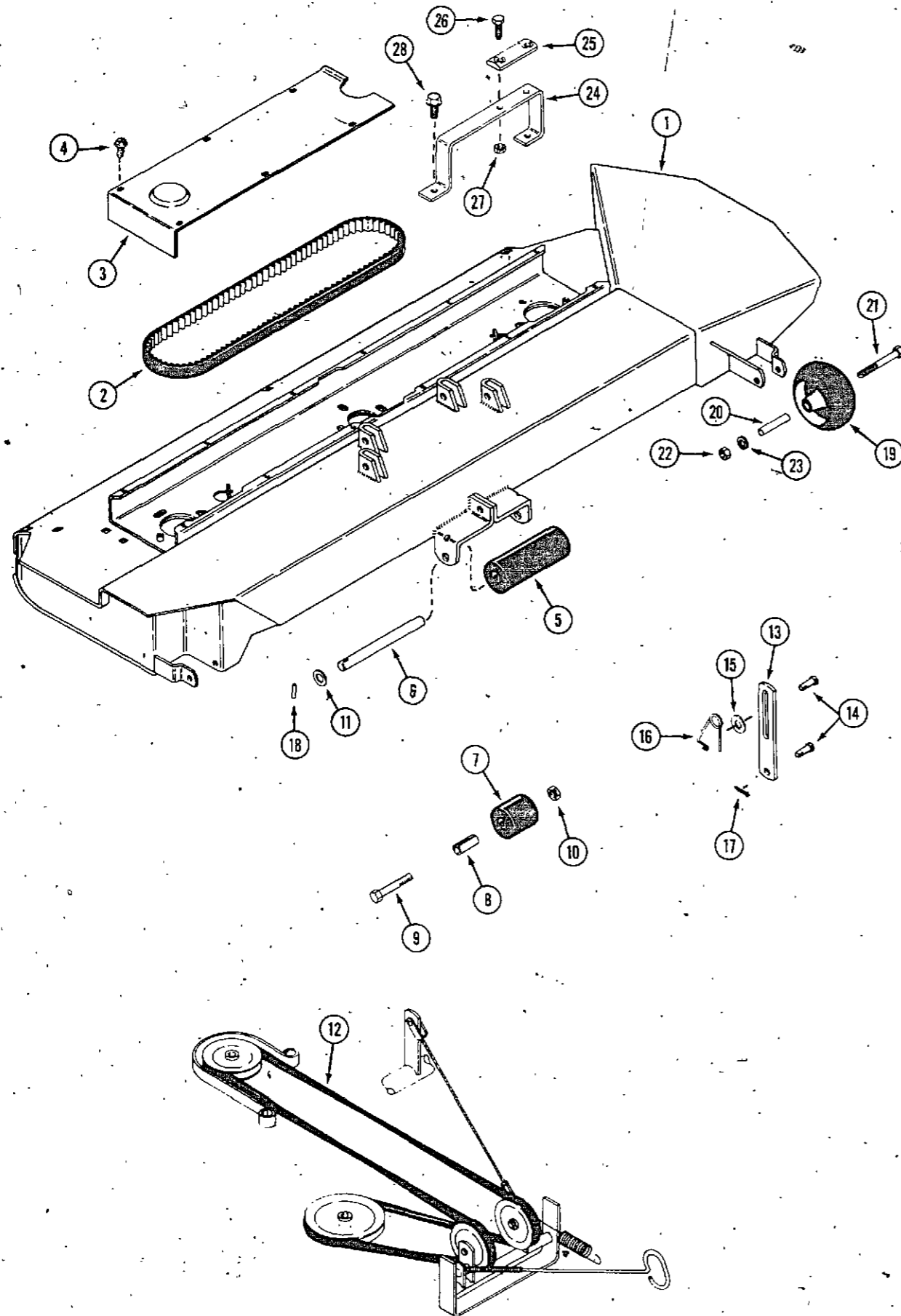

REF.	PART NO.	DESCRIPTION	REQ'D.
1	C 27727	DECK - mower 60" (1520 mm)	1
2	C 25687	BELT - spindle drive	2
3	C 25689	COVER - deck belt	2
4	187- 1036	SCREW - 1/4" - 20 x 1/2" self-tapping	10
5	A 70524	ROLLER - 2-1/2" x 7" (64 x 178 mm)	1
6	C 26405	SHAFT - roller	1
7	A 70514	ROLLER - 2-1/2" x 2-3/8" (64 x 60 mm)	4
8	C 25620	SPACER - sleeve	4
9	113- 447	BOLT - 1/2" - 13 x 3-1/2" hex	4
10	131- 1182	NUT - lock 1/2" hex	6
11	195- 541	WASHER - 5/8"	1
12	C 27686	BELT - "V" mower drive	1
13	C 18338	LINK - mower lift	2
14	C 10821	PIN - clevis	4
15	195- 533	WASHER - 1/2"	2
16	C 10898	PIN - retaining, special	2
17	132- 310	PIN - cotter	2
18	138- 106	PIN - roll 3/16" x 2-1/2"	1
19	C 27730	WHEEL - anti-scalp	2
20	C 27731	SPACER - sleeve	2
21	113- 252	BOLT - 3/8" - 16" x 3-3/4"	2
22	129- 103	NUT - 3/8" - 16	2
23	192- 21	LOCK WASHER - 3/8"	2
24	C 27639	BRACKET - belt brake	1
25	C 27640	PAD - belt brake	2
26	113- 102	BOLT - 5/16" x 3/4"	4
27	131- 176	NUT - lock 5/16"	4
28	187- 1073	SCREW - 1/4" - 20 x 5/8" self-tapping	2

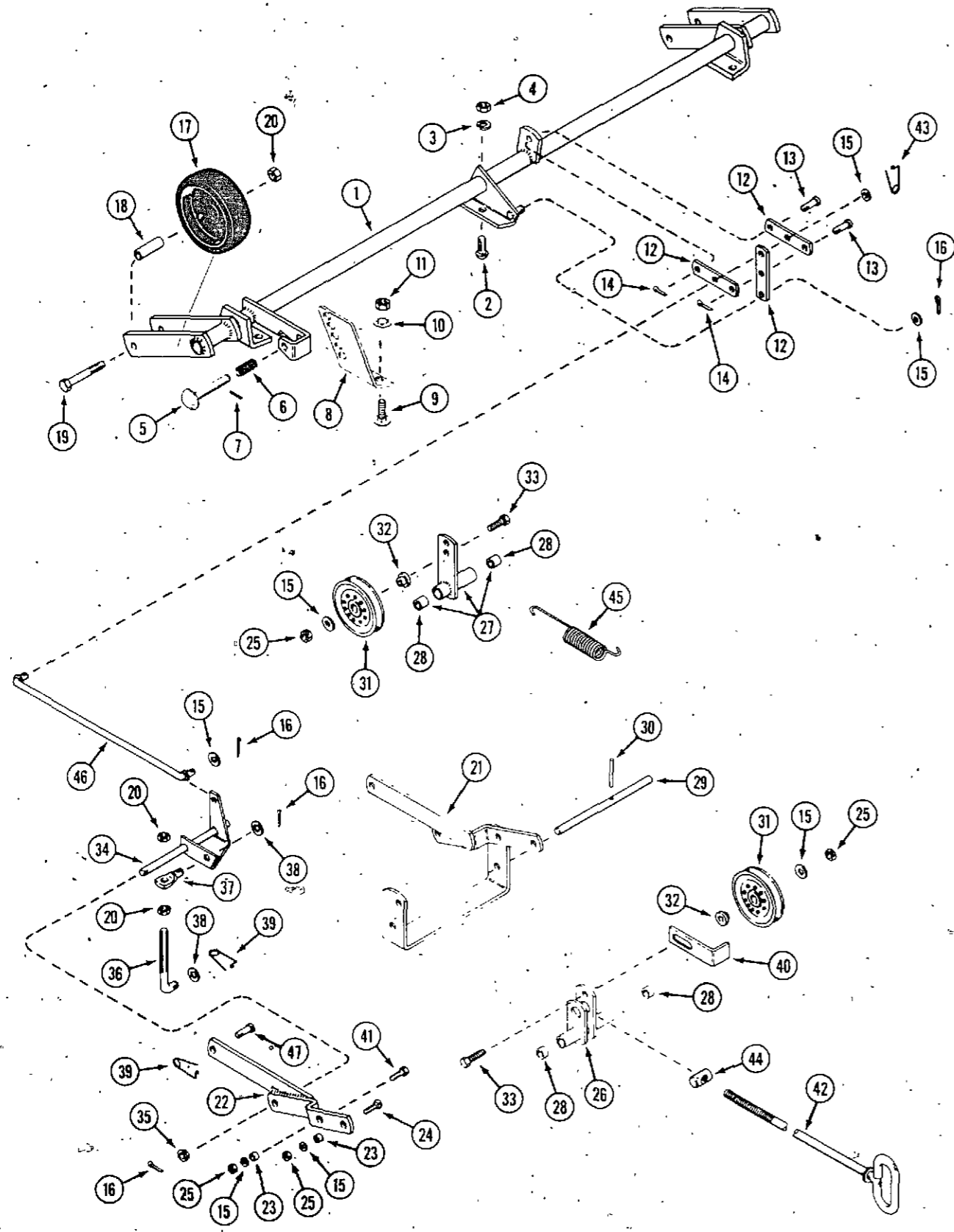

AXLE AND MOUNTING BRACKETS

REF.	PART NO.	DESCRIPTION	REQ'D.
1	C 26413	AXLE - rear	1
2	111- 371	BOLT - carriage 3/8" - 16 x 1"	6
3	192- 21	LOCK WASHER - 3/8"	6
4	129- 103	NUT - 3/8" - 16 hex	6
5	C 20005	PIN - locking	1
6	C 10482	SPRING - tension	1
7	138- 96	PIN - roll	1
8	C 15935	BRACKET - height adjust	1
9	111- 202	BOLT - carriage 5/16" - 18 x 3/4"	2
10	193- 29	LOCK WASHER - 5/16"	2
11	129- 102	NUT - 5/16" - 18 hex	2
12	C 26384	LINK - rock arm	2
13	141- 4	PIN - clevis 3/8"	3
14	132- 321	PIN - cotter 3/32" x 1"	2
15	195- 525	WASHER - 3/8"	2
16	132- 310	PIN - cotter 1/8" x 1"	9
17	C 25682	WHEEL - height adjust	7
18	C 25683	SPACER - sleeve	2
19	113- 447	BOLT - 1/2" - 13 x 3-1/2"	2
20	131- 1182	NUT - lock 1/2" - 13 hex	2
	C 27705	CARRIAGE ASSEMBLY	4
21	C 27721	BRACKET - L.H. tow and yoke	1
22	C 27720	LINK - tow R.H.	1
23	C 16573	SPACER - sleeve	1
24	111- 366	BOLT - carriage 3/8" - 16 x 1-1/4"	3
25	131- 1181	NUT - lock 3/8" - 16 hex	2
26	C 27691	ARM - idler adjusting	4
27	C 26394	ARM - idler pulley, spring loaded	1
28	C 17597	BEARING - sleeve	1
29	C 27695	SHAFT - pivot	2
30	138- 106	PIN - roll 3/16" x 2-1/2"	1
31	C 25370	PULLEY - idler	1
32	C 12264	BUSHING - pulley	2
33	113- 209	BOLT - 3/8" - 16 x 1-1/2" hex	2
34	C 26389	BELL CRANK	2
35	C 12127	BUSHING - nylon, flange	1
36	C 19502	BOLT - "J"	2
37	C 26033	PIN - adjust	1
38	195- 533	WASHER - 1/2"	1
39	C 10898	PIN - safety	2
40	C 20013	KEEPER - belt	3
41	113- 208	BOLT - 3/8" - 16 x 1-1/4" hex	1
42	C 27688	SCREW - idler adjust	2
43	C 10883	PIN - safety	1
44	C 14269	NUT - adjust, special	1
45	C 26386	SPRING - tension	1
46	C 27821	LINK - leveler	1
47	C 10821	PIN - clevis	2

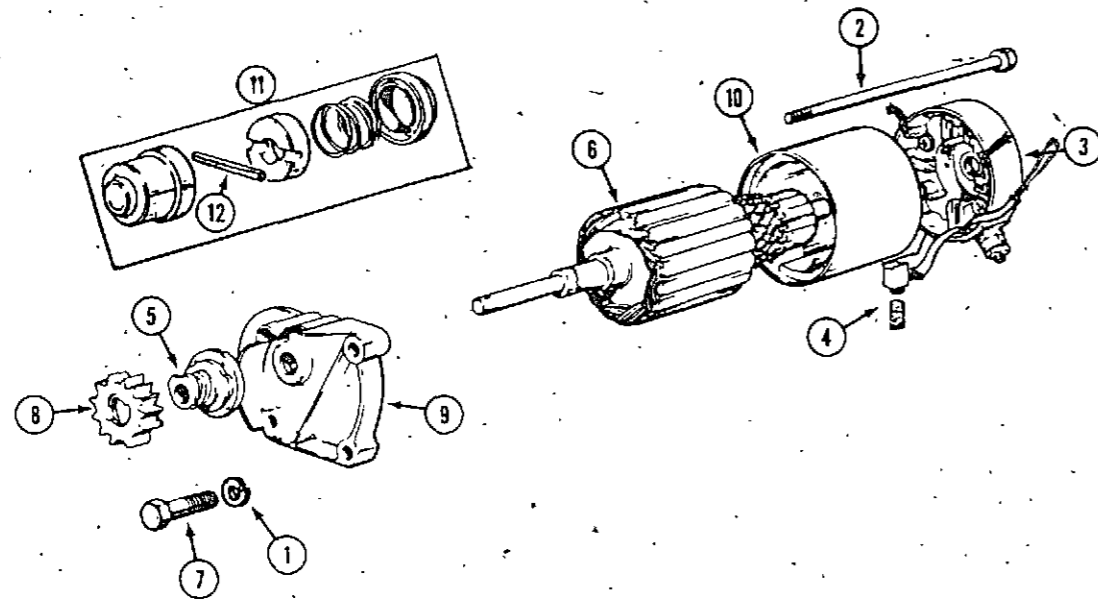

STARTER MOTOR (2486)

REF.	PART NO.	DESCRIPTION	REQ'D
	C 27418	MOTOR - starting	1
1	192- 20	LOCK WASHER - 5/16"	2
2	C 27260	BOLT - thru	2
3	C 27258	END CAP ASSEMBLY - commutator end	1
4	C 27259	BRUSH SET	2
5	C 27421	CLUTCH - drive	1
6	BR 390837	ARMATURE	1
7	113- 122	SCREW - mounting 5/16" - 18 x 1-1/2"	2
8	C 27422	GEAR - drive	1
9	C 27423	END CAP - drive end	1
10	C 27263	HOUSING - starter	1
11	C 27424	KIT - pinion spring	1
12	138- 75	PIN - roll 5/32" x 7/8"	1

STARTER MOTOR (2480)

	C 27264	MOTOR - starter, 12 volt	1
1	C 27260	BOLT - thru (includes washer)	2
2	C 27259	BRUSH ASSEMBLY	1
3	BR 391461	DRIVE ASSEMBLY - starter	1
4	BR 390837	ARMATURE - starter	1
5	C 27262	END CAP - drive end	1
6	C 27258	END CAP - commutator end	1
7	C 27263	HOUSING - starter	1

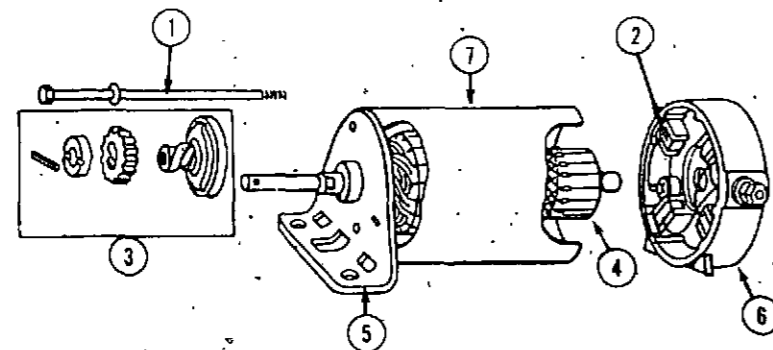

ELECTRICAL SYSTEM

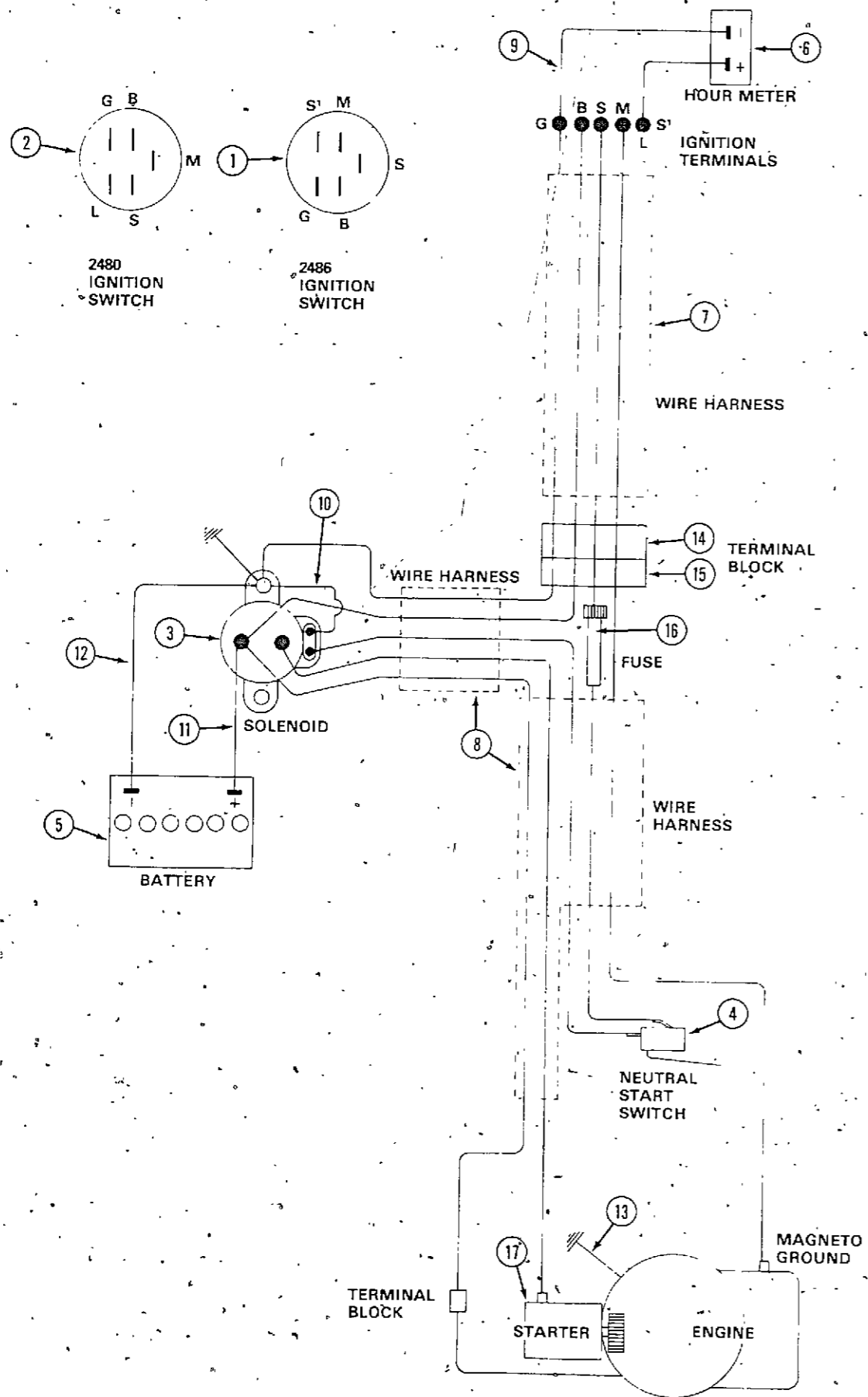

REF.	PART NO.	DESCRIPTION	REQ'D.
1	C 27121	SWITCH - ignition (2486)	1
2	C 24145	SWITCH - ignition (2480)	1
	C 27751	KEY - ignition	1
3	C 27523	SOLENOID - start	1
4	C 27549	CONNECTOR - solenoid	1
	C 24800	SWITCH - neutral start	1
5	C 18197	BATTERY - 12 volt	1
	C 18113	CAP - battery	6
6	L 49907	HOUR METER	1
7	C 27681	HARNESS - wire, front (2480)	1
7	C 27756	HARNESS - wire, front (2486)	1
8	C 27717	HARNESS - wire, rear (2480)	1
8	C 27757	HARNESS - wire, rear (2486)	1
9	C 27683	WIRE - hour meter	1
10	C 27682	WIRE - solenoid to ground	1
11	C 27521	WIRE - battery positive	1
12	C 27528	WIRE - battery negative	1
13	C 24816	WIRE - ground (2480)	1
14	C 27685	BLOCK - terminal (pin)	1
15	C 27684	BLOCK - terminal (socket)	1
16	223- 20	FUSE - 20 amperes (included in harness)	1
17	C 27418	MOTOR - starting (2486) repairs page 41	1
17	C 27264	MOTOR - starting (2480) repairs page 41	1

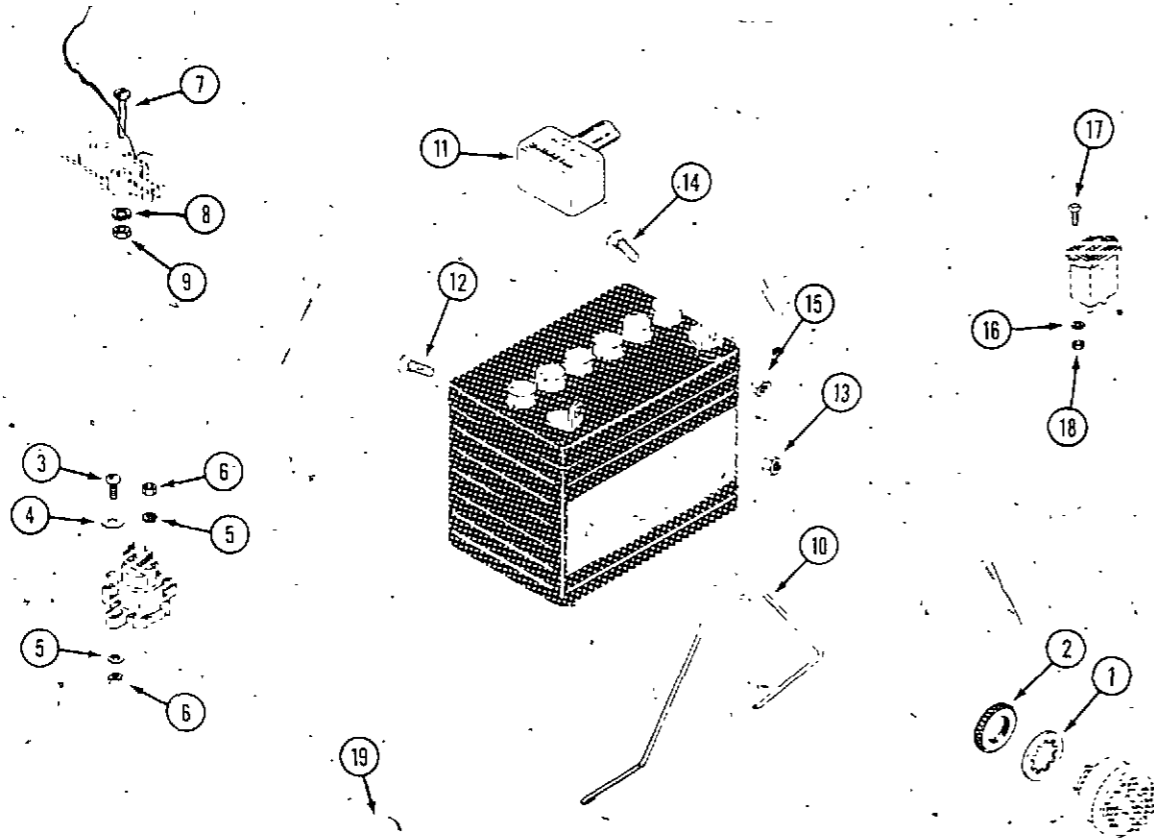

ELECTRICAL SYSTEM HARDWARE

REF.	PART NO.	DESCRIPTION	REQ'D.
1	C 23248	LOCK WASHER - internal tooth 5/8"	1
2	C 24659	NUT - 5/8" - 32 knurled	1
3	182- 147	SCREW - No. 10 - 32 x 3/4"	2
4	195- 513	WASHER - No. 10	3
5	192- 18	LOCK WASHER - 3/16"	4
6	129- 37	NUT - No. 10 - 32	4
7	182- 10	SCREW - No. 4 - 40 x 7/8"	2
8	192- 13	LOCK WASHER - No. 4	2
9	129- 13	NUT - No. 4 - 40	2
10	C 16239	CLAMP - battery hold down	1
11	C 24069	COVER - terminal	1
12	111- 202	BOLT - 5/16" - 18 x 3/4" carriage	1
13	129- 102	NUT - 5/16" - 18	1
14	111- 108	BOLT - 1/4" - 20 x 3/4" carriage	1
15	129- 101	NUT - 1/4" - 20	1
16	192- 15	LOCK WASHER - No. 6	2
17	182- 571	BOLT - No. 6 - 32 x 1/2"	2
18	129- 15	NUT - No. 6 - 32	2
19	C 22947	STRAP - tie	6

DECALS

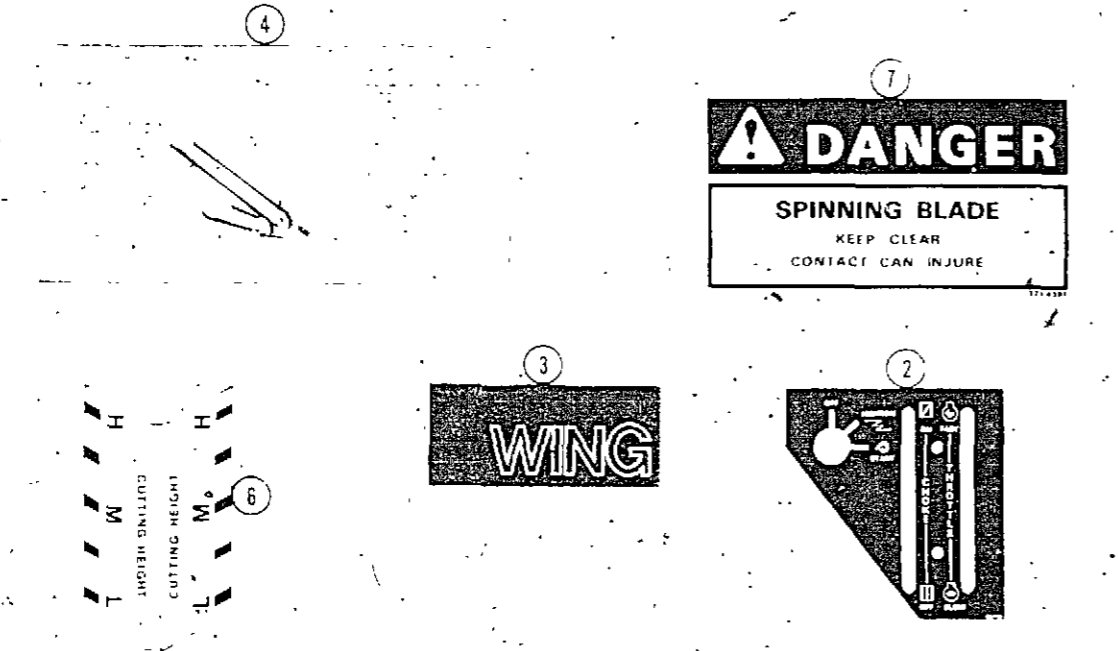
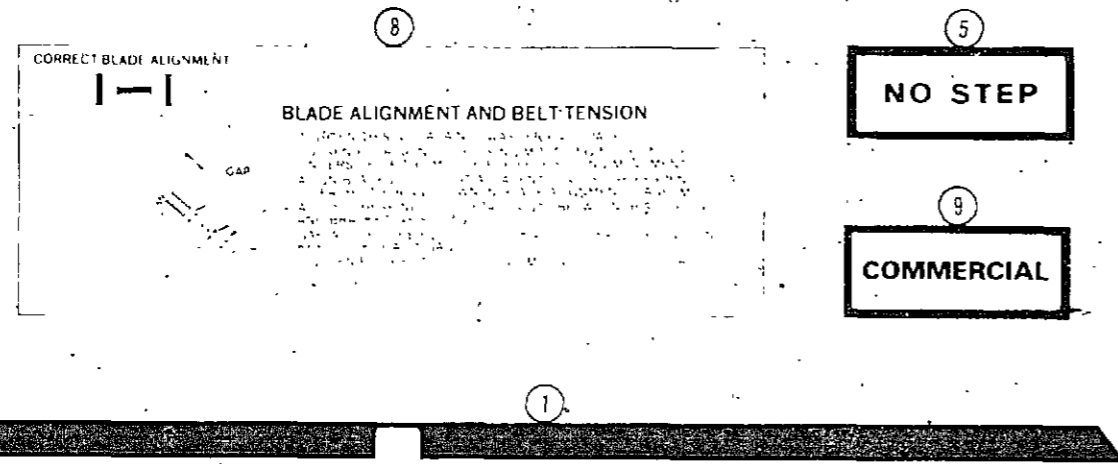

REF.	PART NO.	DESCRIPTION	REQ'D.
1	C 27697	DECAL - hood L.H: (shown)	1
1	C 27698	DECAL - hood R:H.	1
2	C 27699	DECAL - instrument tower (2480)	1
2	C 27700	DECAL - instrument tower (2486) shown	1
3	C 27701	DECAL - logo	1
4	C 27702	DECAL - drive belt adjust	1
5	C 12519	DECAL - "No Step"	2
6	321- 6210	DECAL - cutting height	1
7	321- 4381	DECAL - "Spinning Blade"	1
8	321- 6236	DECAL - spindle drive belt	2
9	321- 6263	DECAL - "Commercial"	1

NUMERICAL INDEX

PART NO.	PAGE NO.	REF. NO.	PART NO.	PAGE NO.	REF. NO.	PART NO.	PAGE NO.	REF. NO.
A	27795	17	BR	299500	17	C	22947	45
A	30338	29	BR	299707	11	C	23248	45
A	30881	35	BR	299740	11	C	24069	45
A	67313	31	BR	299852	11	C	24137	29
A	70280	35	BR	390419	7	C	24145	43
A	70282	27	BR	390684	11	C	24329	9
A	70282	33	BR	390837	41	C	24502	27
A	70282	35	BR	390837	41	C	24503	27
A	70514	37	BR	391233	11	C	24659	45
A	70524	37	BR	391406	5	C	24800	43
BR	22963	5	BR	391461	41	C	24816	43
BR	26157	11	BR	391512	11	C	25369	31
BR	26157	13	BR	391733	17	C	25370	39
BR	26828	5	BR	392134	9	C	25468	21
BR	28828	7	BR	393456	9	C	25469	15
BR	27803	5	BR	393474	9	C	25500	15
BR	65906	5	C	10482	39	C	25541	35
BR	65906	7	C	10657	23	C	25543	35
BR	66068	17	C	10810	35	C	25620	37
BR	66538	9	C	10821	37	C	25627	35
BR	66554	17	C	10821	39	C	25631	35
BR	66768	5	C	10883	39	C	25632	35
BR	93113	7	C	10898	37	C	25635	35
BR	93323	11	C	10898	39	C	25637	35
BR	93357	11	C	11529	23	C	25639	35
BR	93499	11	C	12127	39	C	25642	35
BR	93499	13	C	12224	21	C	25643	35
BR	93499	13	C	12264	39	C	25644	35
BR	93622	11	C	12519	47	C	25645	35
BR	93630	7	C	12718	27	C	25682	39
BR	93723	5	C	12975	29	C	25683	39
BR	211712	11	C	13385	27	C	25687	37
BR	220865	9	C	14269	39	C	25688	35
BR	221535	17	C	14399	5	C	25689	37
BR	221596	5	C	14399	7	C	25701	15
BR	221596	7	C	14506	21	C	25709	5
BR	221798	9	C	14652	17	C	25709	7
BR	221995	11	C	14728	29	C	25710	5
BR	222010	11	C	14906	5	C	25711	5
BR	222010	13	C	14906	7	C	25712	5
BR	222014	11	C	15389	31	C	25713	5
BR	222450	17	C	15935	39	C	25714	5
BR	222561	9	C	16239	45	C	25715	5
BR	222562	9	C	16362	33	C	25716	5
BR	230896	11	C	16373	29	C	25717	5
BR	230896	13	C	16516	35	C	25718	5
BR	230932	11	C	16573	39	C	25718	7
BR	231055	5	C	17597	39	C	25719	9
BR	231058	17	C	17666	35	C	25720	5
BR	261116	11	C	18113	43	C	25721	5
BR	261129	17	C	18197	43	C	25722	5
BR	270382	11	C	18251	31	C	25723	5
BR	270511	11	C	18338	37	C	25724	5
BR	292260	7	C	18814	7	C	25725	5
BR	292681	11	C	19473	5	C	25726	5
BR	292681	13	C	19502	39	C	25727	5
BR	299096	11	C	20005	39	C	25728	5
BR	299096	13	C	20013	39	C	25728	7
BR	299500	17	C	21901	29	C	25729	5

NUMERICAL INDEX

PART NO.	PAGE NO.	REF. NO.	PART NO.	PAGE NO.	REF. NO.	PART NO.	PAGE NO.	REF. NO.
C	25729	7	C	27260	41	C	27357	9
C	25730	5	C	27260	41	C	27358	9
C	25730	7	C	27262	41	C	27359	19
C	25731	5	C	27263	41	C	27360	19
C	25732	5	C	27263	41	C	27362	19
C	25733	5	C	27264	41	C	27363	19
C	25733	7	C	27264	43	C	27364	15
C	25734	5	C	27266	11	C	27365	9
C	25735	5	C	27267	11	C	27366	15
C	25736	5	C	27268	11	C	27367	15
C	25737	5	C	27269	9	C	27368	19
C	25738	11	C	27270	9	C	27369	19
C	25742	11	C	27273	19	C	27370	19
C	25744	17	C	27308	7	C	27371	7
C	25746	5	C	27309	19	C	27372	7
C	25747	17	C	27310	7	C	27373	7
C	25749	7	C	27311	7	C	27374	7
C	25751	5	C	27312	7	C	27375	13
C	25752	5	C	27313	7	C	27376	13
C	25757	5	C	27314	7	C	27377	13
C	25758	11	C	27315	7	C	27378	13
C	25759	11	C	27316	7	C	27379	13
C	25760	11	C	27317	7	C	27380	13
C	25762	11	C	27318	7	C	27381	13
C	25763	17	C	27319	7	C	27382	13
C	25764	11	C	27320	7	C	27383	13
C	25781	35	C	27321	7	C	27384	13
C	25827	5	C	27322	7	C	27385	13
C	25829	35	C	27323	7	C	27386	13
C	25846	29	C	27324	7	C	27387	13
C	26033	39	C	27325	7	C	27388	13
C	26188	31	C	27326	7	C	27389	13
C	26197	9	C	27327	7	C	27390	15
C	26198	9	C	27328	7	C	27391	17
C	26199	9	C	27329	7	C	27392	13
C	26358	11	C	27330	7	C	27393	13
C	26384	39	C	27331	7	C	27394	13
C	26386	39	C	27332	17	C	27395	17
C	26389	39	C	27333	13	C	27396	17
C	26394	39	C	27334	9	C	27397	17
C	26405	37	C	27335	7	C	27398	17
C	26413	39	C	27336	7	C	27399	13
C	26495	31	C	27337	7	C	27400	13
C	26507	15	C	27338	7	C	27401	13
C	26526	27	C	27339	7	C	27402	13
C	26697	23	C	27340	17	C	27403	13
C	26848	25	C	27341	17	C	27404	15
C	27059	19	C	27342	7	C	27405	15
C	27121	43	C	27343	17	C	27406	15
C	27236	5	C	27344	17	C	27407	13
C	27236	7	C	27345	7	C	27408	15
C	27238	5	C	27346	7	C	27409	13
C	27240	11	C	27347	7	C	27410	15
C	27240	13	C	27348	19	C	27411	15
C	27244	11	C	27349	19	C	27412	13
C	27253	9	C	27350	19	C	27413	13
C	27257	17	C	27351	9	C	27414	13
C	27258	41	C	27352	9	C	27415	13
C	27258	41	C	27353	15	C	27416	13
C	27259	41	C	27354	15	C	27417	15
C	27259	41	C	27355	19	C	27418	41

NUMERICAL INDEX

PART NO.	PAGE NO.	REF. NO.	PART NO.	PAGE NO.	REF. NO.	PART NO.	PAGE NO.	REF. NO.	PART NO.	PAGE NO.	REF. NO.	PART NO.	PAGE NO.	REF. NO.	PART NO.	PAGE NO.	REF. NO.		
C	27418	43	17	C	27703	23	6	113-	417	29	3	163-	4	13	28	195-	513	45	4
C	27419	9	13	C	27705	39		113-	424	29	21	163-	4	17	18	195-	518	17	9
C	27420	9	12	C	27713	31	9	113-	426	29	3	169-	137	15	3	195-	518	33	6
C	27421	41	5	C	27714	31	10	113-	447	37	9	177-	97	13	33	195-	521	35	20
C	27422	41	8	C	27715	31	11	113-	447	39	19	178-	858	25	2	195-	525	31	11
C	27423	41	9	C	27716	31	12	123-	101	35	16	182-	10	45	7	195-	525	39	15
C	27424	41	11	C	27717	43	8	126-	16	35	10	182-	49	13	40	195-	529	25	4
C	27521	43	11	C	27720	39	22	129-	13	45	9	182-	84	9	4	195-	533	9	5
C	27523	43	3	C	27721	39	21	129-	15	45	18	182-	87	11	4	195-	533	37	15
C	27528	43	12	C	27727	37	1	129-	16	17	2	182-	87	13	21	195-	533	39	38
C	27549	43		C	27730	37	19	129-	16	17	13	182-	87	17	10	195-	541	37	11
C	27582	7	21	C	27731	37	20	129-	16	19	16	182-	90	9	10	195-	2069	29	16
C	27583	7	52	C	27747	21	1	129-	17	17	7	182-	147	45	3	214-	251	13	42
C	27611	33	1	C	27751	43		129-	17	21	8	182-	205	13	7	214-	251	23	4
C	27612	33	1	C	27756	43	7	129-	17	33	14	182-	549	9	16	218-	508	31	13
C	27620	31	9	C	27757	43	8	129-	37	45	6	182-	571	45	17	218-	5479	31	7
C	27627	33	3	C	27775	33	4	129-	101	15	2	182-	573	21	6	219-	10	27	3
C	27630	33	11	C	27814	31	1	129-	101	17	11	182-	573	33	12	219-	20	33	2
C	27631	23	1	C	27821	39	46	129-	101	31	10	187-	1036	23	2	221-	86	5	39
C	27632	23	1	C	27977	27	5	129-	101	45	15	187-	1036	29	12	221-	86	7	48
E	27633	23	3	C	27981	27	2	129-	102	35	21	187-	1036	37	4	221-	843	5	11
C	27634	23	7	L	49907	43	6	129-	102	39	11	187-	1041	15	1	221-	843	7	11
C	27635	33	10	T	25070	25	10	129-	102	45	13	187-	1041	15	12	223-	20	43	16
C	27636	25	1					129-	103	31	5	187-	1047	7	38	321-	4381	47	7
C	27637	21	2					129-	103	37	22	187-	1073	37	28	321-	6210	47	6
C	27638	21	3					129-	103	39	4	187-	1334	29	10	321-	6236	47	8
C	27639	37	24					129-	105	9	7	187-	1508	5	7	321-	6263	47	9
C	27640	37	25					131-	176	21	3	187-	1508	19	9				
C	27641	31	6					131-	176	31	16	187-	1510	11	37				
C	27644	31	1					131-	176	35	22	187-	1510	17	22				
C	27646	31	2					131-	176	37	27	192-	13	45	8				
C	27647	31	5					131-	666	35	15	192-	15	45	16				
C	27648	31	6					131-	911	9	8	192-	18	7	33				
C	27649	29	1					131-	934	23	5	192-	18	13	29				
C	27655	29	7					131-	934	33	19	192-	18	17	19				
C	27665	29	8					131-	1181	25	9	192-	18	21	7				
C	27666	29	8					131-	1181	39	25	192-	18	33	13				
C	27668	29	11					131-	1182	37	10	192-	18	45	5				
C	27669	29	17					131-	1182	39	20	192-	19	13	6				
C	27670	29	19					131-	1216	35	3	192-	19	15	7				
C	27671	29	20					131-	1331	35	13	192-	19	15	17				
C	27676	29	23					132-	46	33	8	192-	19	17	13				
C	27677	29	24					132-	310	31	4	192-	19	19	4				
C	27679	33	17					132-	310	31	12	192-	20	7	45				
C	27681	43	7					132-	310	37	17	192-	20	9	10				
C	27682	43	10					132-	310	39	16	192-	20	19	13				
C	27683	43	9					132-	311	27	7	192-	20	41	1				
C	27684	43	15					132-	311	33	15	192-	21	31	4				
C	27685	43	14					132-	321	39	14	192-	21	37	23				
C	27686	37	12					132-	329	31	8	192-	21	39	3				
C	27687	25	6					132-	378	33	5	192-	23	9	6				
C	27688	39	42					136-	103	17	16	192-	23	29	4				
C	27691	39	26					138-	75	41	12	192-	23	29	22				
C	27695	39	29					138-	96	39	7	193-	25	9	5				
C	27697	47	1					138-	106	37	18	193-	25	17	3				
C	27698	47	1					138-	106	39	30	193-	25	17	12				
C	27699	47	2					138-	251	11	6	193-	29	39	10				
C	27700	47	2					138-	248	25	7	195-	10	9	11				
C	27701	47	3					138-	252	37	21	195-	136	25	8				
C	27702	47	4					138-	268	35	2	195-	513	13	34				

HARDWARE CODE NUMBERS

14-	712	25	3
22-	48	15	16
22-	48	17	12
22-	48	19	3
41-	24	11	12
111-	2	17	6
111-	101	33	18
111-	108	45	14
111-	202	39	9
111-	202	45	12
111-	366	39	24
111-	371	35	14
111-	371	39	2
111-	404	17	10
111-	534	9	4
113-	1	15	6
113-	1	23	4
113-	2	15	13
113-	5	13	5
113-	101	19	12
113-	102	9	9
113-	102	37	26
113-	103	31	15
113-	104	21	2
113-	110	21	2
113-	120	7	44
113-	122	41	7
113-	138	15	4
113-	206	31	3
113-	206	35	4
113-	208	39	41
113-	209	39	33
113-	248	25	7
113-	252	37	21
113-	268	35	2

NUMERICAL INDEX